The logo for ENTURY, featuring the word "ENTURY" in a stylized, outlined font. The letters are interconnected, with the 'E' and 'N' sharing a vertical stroke, and the 'Y' having a long horizontal tail that extends to the right. A small "TM" trademark symbol is located at the end of the horizontal tail.

ENTURY™

The background of the page is filled with white line-art illustrations of various industrial tools and fasteners. These include a large circular component with internal vanes, several bolts of different sizes and orientations, a hexagonal nut, a long threaded rod, and a smaller cylindrical fastener. The drawings are scattered across the page, creating a sense of technical precision and variety.

**HERRAMIENTAS
DE ALTA
RESISTENCIA Y
PRESICIÓN**

Heavy duty precision tools

2022

ENTURY™

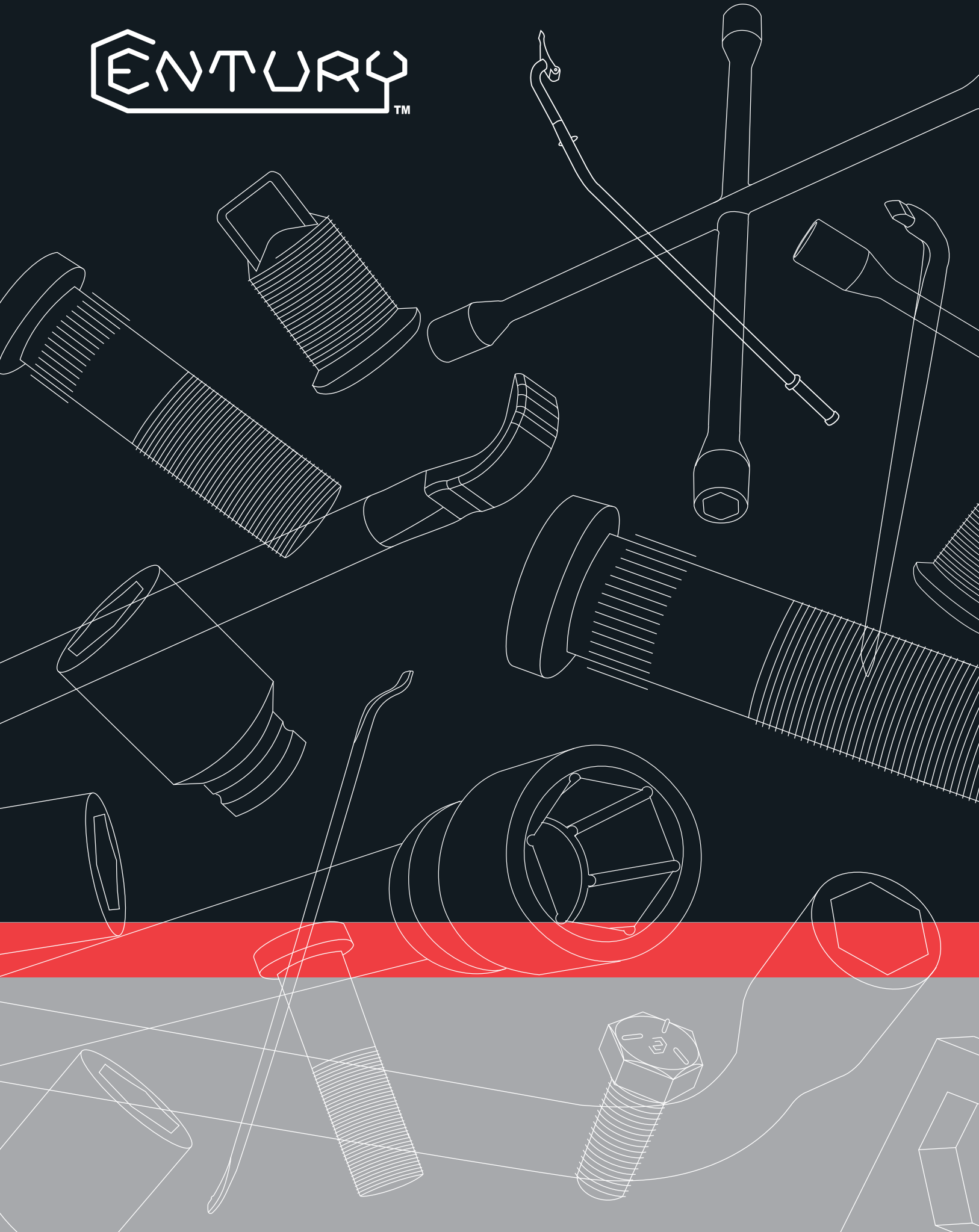

■ 1. Índice / Index	1,2
■ 2. Introducción / Introduction	3,4
■ 3. Herramientas de alta resistencia para el cambio de ruedas en la industria automotriz / Heavy duty precision tools for the wheels removal in the automotive industry.....	5
Dados de impacto hexagonales para cambio de ruedas con cuadro de 1/2"	
/ 6 point wheel service impact socket 1/2" DR.....	5
Dados de impacto hexagonales para cambio de ruedas con cuadro de 3/4"	
/ 6 point wheel service impact socket 3/4" DR.....	5
Dados de impacto hexagonales para cambio de ruedas con cuadro de 1"	
/ 6 point wheel service impact socket 1" DR.....	6
Dados de impacto hexagonales de pared delgada para rin deportivo	
/ Hexagonal impact socket extra thin wall wheel protector.....	6
Dados de impacto de pared delgada con cuadro de 1/2"	
/ 6 point Impact socket extra thin wall 1/2" DR.....	6
Dados de impacto de pared delgada con cuadro de 3/4"	
/ 6 point Impact socket extra thin wall 3/4" DR.....	6
Dados de impacto fliper doble boca de pared delgada con cuadro de 1/2" en pared central	
/ 6 point dual opening budd wheel flip impact socket 1/2" DR.7.....	6
Dados de impacto hexagonales combinados con cuadro interior	
/ Hexagonal and inside square combo impact socket.....	7
Dados de impacto de doble cuadro / Doble square impact socket.....	7
■ 4. Herramientas especiales para el cambio de ruedas / Special impact tools for wheels.....	8
Tuerca extractor de capuchón y herramienta de golpe de uso rudo / Impact Inner cap nut remover kit.....	8
Extractor de capuchón con hexágono exterior / External hexagonal dual wheel lug stud remover.....	8
Llave cometa / Backup lug nut wrench.....	8
Llaves de cruz / Cross wrenches.....	9
Llaves de artillería milimétricas / Milimetric single and double ended wrenches.....	10
Llaves de artillería en medida estándar (pulgadas) / Standard single and double ended wrenches.....	11
■ 5. Manerales de alta resistencia al torque / Heavy duty handels.....	12
Llaves en "L" / "L" shape wrenches.....	12
Manerales para llaves de artillería / Wrench handle bars.....	12
Manerales con cuadro exterior / External square handle.....	12
Maneral corredizo / Sliding T-bar.....	13
Maneral en "L" / "L" handle.....	13
Maneral articulado / Flexible handle.....	13
Kit de repuesto para maneral articulado de 1/2" / Articulated replacement kit for flexible handle 1/2" DR.....	13
■ 6. Herramientas de alta resistencia para desmontar y montar llantas / Heavy duty impact bead breakers.....	14
Espátulas / Lock ring and Bead Breakers.....	14
Marros talache y barra de golpe / Bead breaking hammers and heavy duty beadbreaker slide hammer bars for tires..	15
Separador de ceja y herramientas para montar y desmontar llantas sin cámara	
/ Tire changing tool and bead keeper.....	15
Multiplicador de torque / Torque multiplier.....	15
■ 7. Herramientas de alta resistencia para el uso constante / Heavy duty tools.....	16
Gatos hidráulicos de botella para trabajo pesado / Heavy duty bottle jack.....	16
Pistolas neumáticas / Heavy duty pneumatic wrenches.....	16
■ 8. Juegos para el cambio constante de llantas / Heavy duty kits.....	17
Juego de dados de impacto hexagonales con cuadro de 1/2" para cambio de ruedas con adaptador y nudo	
/ 6 point wheel service impact socket 1/2" DR, with adapter and universal join set.....	17
Juego de dados de impacto hexagonales con cuadro de 3/4" para cambio de ruedas con adaptador y nudo	
/ 6 point wheel service impact socket 3/4" DR, with adapter and universal join set.....	17
Juegos de dados de impacto hexagonales con cuadro de 3/4" para cambio de ruedas con adaptador y nudo	
/ 6 point wheel service impact socket 3/4" DR, with adapter and universal join set.....	17
Juego de dados de impacto hexagonales con cuadro de 1" para cambio de ruedas	
/ 6 point wheel service impact socket 1" DR set.....	18
Juego de dados de impacto hexagonales de pared delgada para rin deportivo con cuadro de 1/2"	
/ 6 point extra thin wall impact socket 1/2" DR set.....	18
Juego de 2 dados dobles de impacto hexagonales fliper con cuadro de 1/2" y extensión	
/ 6 point extra thin wall impact socket with 2 end 1/2" DR and extensión set.....	18
Juego removedor de tuercas y seguros (9 piezas) / Lug nut remover socket set (9 Pieces).....	19
Juego tuercas de seguridad / Heavy duty wheel lock set.....	19
Juego tuercas extractor / Impact inner cap nut remover kit.....	19
Juego desmontador / Dismount set.....	19



- 9. Llaves para extraer centros de maza / *Truck spindle nut wrenches*20
 - Dados para centro de maza octagonales y hexagonales / *Truck axel nut sockets 8pt and 6pt*.....20
 - Dado doble octagonal / *Axele nut sockets 8pt double*.....20
- 10. Accesorios de alta resistencia / *Heavy duty accessories*21
 - Dado de torque de 3/4" para suspensión Hendrickson / *Hendrickson suspension socket 3/4" DR*.....21
 - Llave para suspensión Hendrickson / *Hendrickson suspension wrench*.....21
 - Adaptadores de impacto / *Impact adapters*22
 - Adaptadores con perno y liga / *Adapters with pin and o-ring*.....22
 - Extensiones con perno y liga / *Extensions with pin and o-ring*22
 - Accesorios de alto impacto / *Heavy duty accessories*23
 - Extensiones de impacto con cuadro de 1/2" / *Heavy duty extension 1/2" DR*.....23
 - Extensiones de impacto con cuadro de 3/4" / *Heavy duty extension 3/4" DR*.....23
 - Extensiones de impacto con cuadro de 1" / *Heavy duty extension 1" DR*.....23
 - LIGA / *O - ring*.....23
 - Perno candado / *Pin*.....23
 - Adaptadores de impacto articulados / *Heavy duty adapter*.....24
 - Nudo universal de impacto articulado / *Universal-Joint*.....24
 - Nudo universal doble articulación / *Universal Joint*.....24
- 11. Birlos y sujeciones de alta resistencia / *Heavy duty fasteners*.....25
 - Sujeciones, medidas y tipos de cabeza / *Fasteners, measures and types of head*26
 - Tipos de cabeza / *Head Type*26
 - Birlos milimétricos / *Metric studs*.....27
 - Birlos tope / *Double - ended clipped collar shoulder studs*.....35
 - Birlos maza 3/4" / *3/4" studs*37
 - Birlos maza cabeza rin aluminio 1-1/8-16 UNF / *1-1/8 - 16 Thread. Wedged head studs plain body type*43
 - Birlos Volvo Scania / *Volvo Scania studs*46
 - Birlos maza aluminio Scania 7/8"-11 BSF / *7/8"-14 Thread. Volvo wheel studs body type*.....46
 - Birlos maza aluminio Scania 7/8"-14 UNF / *7/8"-14 Thread. Volvo wheel studs body type*47
- 12. Tuerca campana flotante milimétrica pavonada / *2 pieces 33mm, M22x1.5 blacked thread flaged cap wheel nut*.....47
 - Tuercas y capuchones / *Cap nuts and inner cap nuts*48
- 13. Recomendación de uso / *Use recommendation*50
- 14. Equivalencias / *Equivalencies*.....51
- 15. Sistemas de montaje con ruedas / *Wheel mounting system*52
 - Sistemas de montaje de ruedas con guía de maza (Uni-Mount) / *Uni-Mount mounting system*.....52
 - Apriete de tuercas de dos piezas en montaje centrado por maza / *Two-pieces nut tightening in hub-centered mounting*.....53
 - Sistema de montaje de ruedas de asiento cóncavo (Esferico) / *Concave seat wheel mounting system*53
 - Apriete de tuercas con asiento esférico para montaje centrado por birlo / *Tightening nuts with spherical seat for centered mounting of stud*53
- 16. Procesos en nuestras líneas de producción herramientas y sujeciones / *Manufacturing processing line Century studs and tools*.....54
- 17. Tabla de conversiones de milímetros a pulgadas / *Metric - standard conversion chart*.....55
- 18. Garantías / *Warranties*56



Century es una empresa mexicana con más de 40 años de experiencia y presencia internacional en herramientas profesionales para el servicio pesado ganando un prestigio especial en el segmento de cambio de ruedas automotrices. Century es parte del Grupo ETSA, el grupo de tratamiento térmico más grande de México.

Las herramientas Century son utilizadas en el mercado de cambio de ruedas de la industria automotriz y en el segmento mecánico e industrial (petrolero, construcción, eléctrica, metal-mecánica y de maquinaria pesada) que requieren productos con un alto desempeño. En el cambio de ruedas automotrices, Century cuenta con una amplia gama de llaves de cruz, artillería, dados de centro de maza, manerales espátulas, gatos hidráulicos de uso pesado, pistolas neumáticas y herramientas diseñadas para soportar el uso constante que requieren los profesionales. Century así mismo, es líder en la fabricación de accesorios y dados de impacto hexagonales (16mm hasta 70mm o de 3/4" hasta 3-1/4") que garantizan cambios rápidos con alto impacto.

Century ofrece la garantía de precisión y resistencia manteniendo los estándares de calidad más exigentes en todos sus productos. Todas las herramientas cuentan con un diseño basado en: tolerancias cerradas, acero aleado de alta resistencia, paredes robustas, hexagonales y estriadas así como esquinas redondeadas que no permiten que se barra la herramienta. Cada producto está tratado térmicamente para lograr menor desgaste evitar la corrosión e incrementar la resistencia y vida útil de la herramienta con la certificación IATF-16949 e ISO 9001.

Todas las herramientas están manufacturadas bajo los sistemas de calidad ISO-9001 para asegurar la repetibilidad de los procesos logrando así productos de alta resistencia y precisión con una garantía de por vida contra defectos de fabricación.

Para Century es fundamental satisfacer las necesidades de sus clientes por ello ofrece productos de alta calidad que sobrepasan los estándares de la industria garantizando un desempeño extraordinario y una excelente durabilidad también desarrolla constantemente nuevos productos para satisfacer las necesidades del cliente y del mercado. La empresa tiene la capacidad para diseñar y fabricar cualquier medida o nuevo producto que el cliente requiera.



**heavy duty
precision
tools and
fasteners**

LÍDER EN SERVICIO PESADO DE HERRAMIENTAS Y SUJECCIONES

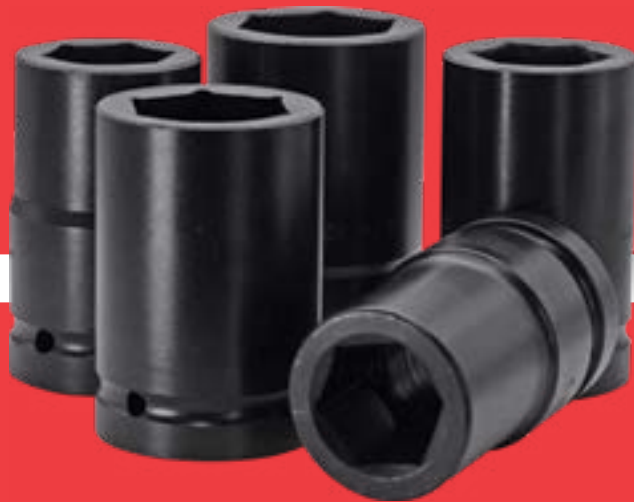

Century is a privately held international Mexican company with over thirty (40) years of experience in the manufacturing of heavy duty impact sockets and hand tools. Century has an irrefutable reputation within the tire-changing field. Century is a division of Grupo ETSA the largest heat treating group in Mexico.

Century's product line is used for tightening or loosening of bolts and nuts in the automotive truck heavy equipment mechanical and general manufacturing industries. Other industries that use Century Tools are petroleum construction electrical mining and down-hole drilling.

Century's is a leader in the design of impact lug wrenches, heavy duty wrenches, impact adaptors, spindle nut wrenches, wheel impact sockets, extensions lock rings, bead breakers bottle jacks, pneumatic air wrenches, security nuts and heavy duty fasteners used in the automotive industry. Century also, produces a complete product line of 6 point (17mm to 70mm and from 3/4" to 3 1/4") and accessories designed for the heavy duty industries.

Century manufactures all products with precision and wear resistance as its primary consideration. All manufactured tools meet or exceed international standards. Century offers a warranty to clients based on superior quality tight tolerances, non-slip surface, design round corners and robust socket walls and corrosion protection. Each product is heat treated to achieve less wear prevent corrosion and increase its resistance and service life of the tool, (Certificates with IATF-16949 e ISO 9001). All Century tools are warranted against manufacturing defects.

When our customers require unique tools with special requirements Century consults with them to determine how to produce to their particular needs.



S33



S3T



S22

HERRAMIENTAS DE ALTA RESISTENCIA PARA EL CAMBIO DE RUEDAS EN LA INDUSTRIA AUTOMOTRIZ

/ HEAVY DUTY PRECISION TOOLS FOR THE WHEELS REMOVAL IN THE AUTOMOTIVE INDUSTRY

Dados de impacto hexagonales para cambio de ruedas con cuadro de 1/2"

/ 6 point wheel service impact socket 1/2" DR.

Modelo Model	Hexágono II	Hexágono mm	Modelo Equivalente	Mando ■	A (mm)	B (mm)	L (mm)	Forma Shape	Peso Kg	Empaque
S17		17 mm	S17M	1/2"	29	29	75	I	0.26	10
S19	3/4"	19 mm	S19M	1/2"	31	31	75	I	0.31	10
S21	13/16"			1/2"	29	29	75	I	0.29	10
S22	7/8"	22 mm	S22M	1/2"	34	34	75	I	0.35	10

Estas herramientas de impacto son para extraer e instalar tuercas y birlos de ruedas automotrices con pistola neumática. Las principales ventajas de estos dados de impacto son: tratamiento térmico especial, paredes robustas, esquinas redondeadas, profundidad en hexágonos y cuadros.

These impact tools remove nuts and studs with pneumatic tools. The main advantages of these impact sockets are: special heat treatment, strong walls, rounded corners and deepness in hexagons and squares.

Dados de impacto hexagonales para cambio de ruedas con cuadro de 3/4"

/ 6 point wheel service impact socket 3/4" DR.

Modelo Model	Hexágono II	Hexágono mm	Modelo Equivalente	Mando ■	A (mm)	B (mm)	L (mm)	Forma Shape	Peso Kg	Empaque
S17T		17 mm	S17MT	3/4"	29	40	75	II	0.48	10
S19T	3/4"	19 mm	S19MT	3/4"	31	40	75	II	0.50	10
S21T	13/16"			3/4"	35	44	75	II	0.62	10
S22T	7/8"	22 mm	S22MT, S23T	3/4"	35	40	75	II	0.56	10
S24T	15/16"	24 mm	S24MT	3/4"	39	43	75	II	0.62	10
S25T	1"			3/4"	41	41	75	I	0.58	10
S27T	1-1/16"	27 mm	S27MT	3/4"	42	42	75	I	0.58	10
S29T	1-1/8"			3/4"	45	45	75	I	0.67	10
S30T	1-3/16"	30 mm	S30MT	3/4"	47	44	75	IV	0.72	10
S32T	1-1/4"	32 mm	S32MT	3/4"	49	44	75	IV	0.76	10
S33T		33 mm	S33MT	3/4"	50	44	75	IV	0.75	10
S3T	1-1/2"	38 mm	S38MT, S3	3/4"	57	45	75	IV	0.98	10
S41T	1-5/8"	41 mm	S41MT	3/4"	62	45	75	IV	1.09	10

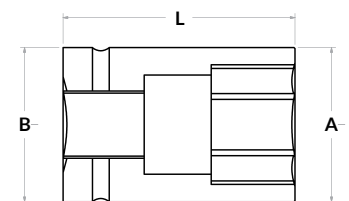

Forma I / Shape I

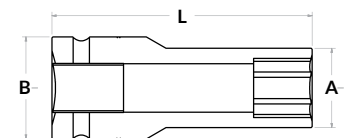

Forma II / Shape II

Modelo equivalente
/ Equivalent model

A: Diámetro exterior en Hexágono
/ Hexagonal external diameter

B: Diámetro exterior en cuadro
/ Squared external diameter

L: Longitud total / Total length



FD1 y FD2



SD 1/2"



SDT 3/4"

Dados de impacto hexagonales para cambio de ruedas con cuadro de 1"
/ 6 point wheel service impact socket 1" DR.

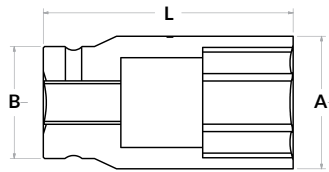

Forma IV / Shape IV

Modelo Model	Hexágono II	Hexágono mm	Modelo Equivalente	Mando ■	A (mm)	B (mm)	L (mm)	Forma Shape	Peso Kg	Empaque
S30P	1-3/16"	30 mm	S30MP	1"	50	50	86	I	0.86	10
S5	1-1/4"	32 mm	S5P, S32MP, S32P	1"	50	50	86	I	0.78	10
S33		33 mm	S33MP	1"	54	52	86	II	1.2	10
S34MP		34 mm		1"	54	54	86	I	1.2	10
S36MP		36 mm		1"	56	54	86	IV	1.2	10
S1	1-1/2"	38 mm	S1P, S38MP, S38P	1"	60	60	86	I	1.2	10
S40MP		40 mm		1"	60	54	86	IV	1.2	10
S41	1-5/8"	41 mm	S41P	1"	63	58	86	IV	3.0	10

DADOS DE IMPACTO HEXAGONALES DE PARED DELGADA PARA RIN DEPORTIVO
/ Hexagonal impact socket extra thin wall wheel protector.

Dados de impacto de pared delgada con cuadro de 1/2"
/ 6 point Impact socket extra thin wall 1/2" DR.

Modelo Model	Hexágono II	Hexágono mm	Mando ■	A (mm)	B (mm)	L (mm)	Forma Shape	Peso Kg	Empaque
SD17	17 mm		1/2"	24	24	74	I	0.14	10
SD19	3/4"	19 mm	1/2"	27	27	74	I	0.18	10
SD21	13/16"		1/2"	29	29	74	I	0.20	10
SD22	7/8"	22 mm	1/2"	30	30	74	I	0.21	10

Garantía limitada, utilice torque adecuado en la pistola neumática / Limited warranty, use the power of the pneumatic air impact wrench gradually.

Dados de impacto de pared delgada con cuadro de 3/4"
/ 6 point Impact socket extra thin wall 3/4" DR.

Modelo Model	Hexágono II	Hexágono mm	Mando ■	A (mm)	B (mm)	L (mm)	Forma Shape	Peso Kg	Empaque
SD19T	3/4"	19 mm	3/4"	28	38	75	II	0.39	10
SD21T	13/16"		3/4"	29	38	75	II	0.41	10

Garantía limitada, utilice torque adecuado en la pistola neumática / Limited warranty, use the power of the pneumatic air impact wrench gradually.

Dado de impacto fliper doble boca de pared delgada con cuadro de 1/2" en pared central
/ 6 point dual opening budd wheel flip impact socket 1/2" DR.

Modelo Model	Hexágono A	Hexágono B	Mando ■	A (mm)	B (mm)	L (mm)	Forma Shape	Peso Kg	Empaque
FD1	17 mm	19 mm	1/2"	24	27	75	0.16	10	10
FD2	19 mm	21 mm	1/2"	27	29	75	0.20	10	10

Garantía limitada, utilice torque adecuado en la pistola neumática / Limited warranty, use the power of the pneumatic air impact wrench gradually.

Dado de impacto doble boca de pared delgada (dos medidas en un dado). En la parte central en el cuadro de 1/2" se coloca la extensión EX3, que viene con el juego SJEFD

Socket with two ends with different sizes (2 sizes one socket). In the middle of each flip socket is a 1/2" drive tang that you slip the extensión EX3, that comes with the set SJEFD.



SIC



S2

Dados de impacto hexagonales combinados con cuadro interior

/ Hexagonal and inside square combo impact socket.

Modelo Model	Hexágono II	Hexágono mm	Cuadro Interior	Mando ■	A (mm)	B (mm)	L (mm)	Forma Shape	Peso Kg	Empaque
S32C	1-1/4"		13/16"	1"	52	56	100	I	1.2	20
S1C	1-1/2"	38 mm	13/16"	1"	59	59	99	I	1.5	20
S41C		41 mm	13/16"	1"	62	62	100	I	1.7	20
S41HC		41 mm	13/16"	1"	63	63	99	I	1.8	20
S32CT	1-1/4"		13/16"	3/4"	50	45	100	IV	1.0	20
S1CT	1-1/2"	38 mm	13/16"	3/4"	57	45	100	IV	1.7	20

Diseñado para acelerar el servicio constante de cambio de ruedas para camiones y trailers. La combinación del hexágono y el cuadro interior del dado, cumple una doble función de ajuste de tuercas, eliminando la necesidad del cambio de herramienta a la mitad del trabajo.

Designed to help speed up wheel servicing on trucks and trailers. The combination hexagonal and inside square socket performs double duty, fitting both nuts and studs, removing the necessity of changing the tool halfway through the job.

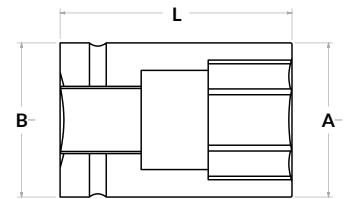

Forma I / Shape I

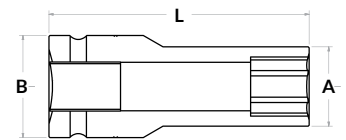

Forma IV / Shape IV

Dados de impacto de doble cuadro

/ Doble square impact socket

Modelo Model	Cuadro II	Cuadro mm	Mando ■	A (mm)	B (mm)	L (mm)	Forma Shape	Peso Kg	Empaque
S7		17 mm	1"	46	50	75	V	0.9	20
S8	3/4"	19 mm	1"	46	50	75	V	0.8	20
S2	13/16"		1"	46	50	76	V	0.8	20
S6		21 mm	1"	46	50	73	V	0.75	20
S10	15/16"		1"	46	50	75	V	0.8	20
S11		20 mm	1"	46	50	76	V	0.7	20
S4	13/16"		3/4"	46	50	73	V	0.8	20
S9		22 mm	1"	46	50	75	V	0.8	20

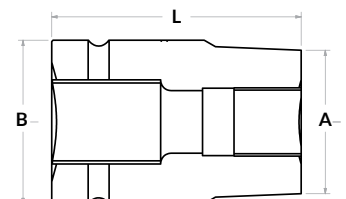

Forma V / Shape V

Modelo equivalente
/ Equivalent model

A: Diámetro exterior en Hexágono
/ Hexagonal external diameter

B: Diámetro exterior en cuadro
/ Squared external diameter

L: Longitud total / Total length



ET



D5S



D13

HERRAMIENTA ESPECIAL PARA EL CAMBIO DE RUEDAS / SPECIAL IMPACT TOOLS FOR WHEELS.

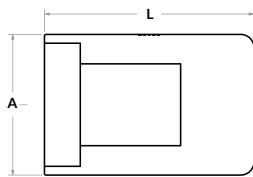
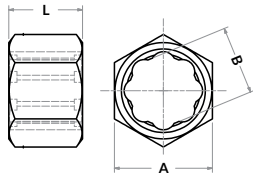

Tuerca extractor de capuchón y herramienta de golpe de uso rudo / Impact inner cap nut remover kit

Modelo Model	Hexágono exterior A	Extractor B	Longitud	Peso Kg	Empaque
ET	1-1/2"	1-1/8"	29 mm	0.13	5
D5S	2"	-	75 mm	0.82	5

Esta herramienta se usa para la extracción de capuchones barridos. La tuerca se usa en ambos lados. Todas nuestras herramientas cuentan con un tratamiento térmico especial para evitar el desgaste y la corrosión. Garantía limitada a 25 extracciones. / Stud remover is use for remove damaged inner cap nuts. All our tools are features rust and corrosion heat treatment resistant. Limited warranty 25 extractions.

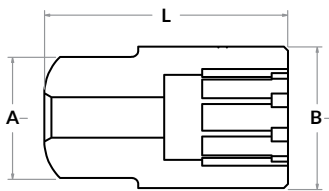

Extractor de capuchón con hexágono exterior / External hexagon dual wheel lug stud remover

Modelo Model	Hexágono exterior A	Extractor B	Longitud	Peso Kg	Empaque
D13	1-1/2"	1-1/8"	76 mm	0.608	25
D13F	1-1/2"	1-3/16"	76 mm	0.628	25

El extractor de capuchón se usa para extraer los capuchones dañados (1-1/8" y 1-3/16") de camiones y trailers de uso pesado. Tratamiento termicamente especial para extender su vida útil. Garantía limitada a 25 extracciones. Stud remover is use for remove damaged inner cap nuts (1-1/8" y 1-3/16" square head) on heavy -duty trucks and trailers. Specially heat treated for an extended life. / limited warranty 50 extractions.

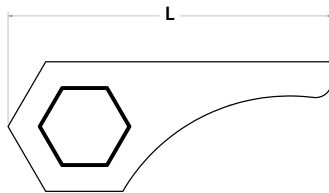

Llave cometa / Backup lug nut wrench

Modelo Model	Hexágono	Longitud	Peso Kg	Empaque
D20	1-1/2"	160 mm	0.468	20

Esta herramienta sirve para detener la contratuerca mientras se extrae el capuchón. This tool holds outer cap nut while turning inner to prevent bolt form rotating.

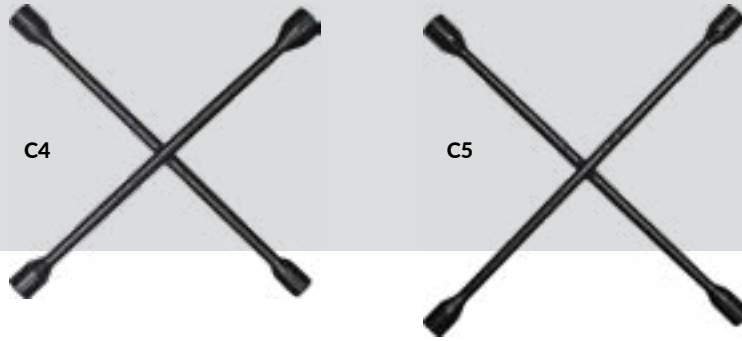

Llaves de cruz
/ Cross wrenches

Modelo Model	Ø	Hexágono A	Hexágono B	Hexágono C	Hexágono / Cuadro D	Longitud	Peso Kg	Empaque
● C2	1"	(41 mm) 1-5/8"	1-1/4" Insq=13/16"	1-1/2" (38 mm)	7/8" (22 mm)	690 mm	6.5	6
● C5L	1"	1-1/2" (38 mm)	15/16"	1-1/4"	1-1/8" Insq=13/16"	690 mm	6.7	5C4
C4	1"	1-1/2" (38 mm)	1-1/8" Insq=13/16"	33 mm	1-1/4"	690 mm	6.5	6
C4C	1"	1-1/2" (38 mm)	Insq=13/16"	33 mm		686 mm	6.6	6
C5	.693"	7/8" (22 mm)	3/4" (19 mm)	17 mm	13/16"	560 mm	2.6	5
● C6	1"	1-5/8" (41 mm)	1-1/16" (27 mm)	1-1/2" (38 mm)	1-1/4" (32mm) Insq=13/16"	686 mm	6.6	6
C7	3/4"	1-1/16" (27 mm)	7/8" (22 mm)	1"	15/16"	660 mm	3.5	5
● C8	1"	1-1/2" (38 mm)	15/16"	1-1/4" (32mm) Insq=13/16"	1-1/16" (27 mm)	690 mm	6.4	6
● C9	3/4"		3/4" (19 mm)	7/8" (22 mm)	13/16"	660 mm	3.4	5
C10	.693"	13/16"	17 mm	3/4" (19 mm)	Espátula Locking	457 mm	2.0	10
C10C	.693"	13/16"	17 mm	3/4" (19 mm)	Outsq: 1/2" (no garantizado)	457 mm	2.0	10
C14	.693"	7/8" (22 mm)	17 mm	13/16"	3/4" (19 mm)	356 mm	1.6	10
● C14E	.612"	7/8" (22 mm)	17 mm	13/16"	3/4" (19 mm)	356 mm	1.4	10
C18	.693"	7/8" (22 mm)	17 mm	13/16"	3/4" (19 mm)	457 mm	2.0	10
C20	.693"	7/8" (22 mm)	17 mm	13/16"	3/4" (19 mm)	508 mm	2.2	10
C26	3/4"	1-1/8"	7/8" (22 mm)	1-1/16" (27 mm)	1"	660 mm	3.6	5

Las llaves de cruz son herramientas manuales automotrices para extraer tuercas y capuchones que sujetan las ruedas de los automóviles, camionetas, camiones, autobuses o trailers. Estas herramientas cuentan con hasta cinco medidas diferentes que pueden sustituir a varias llaves de artillería. Las crucetas están diseñadas para el uso constante del cambio de ruedas.

Cross wrenches are automotive manual tools used for removing nuts and bolts that hold the wheels off cars, pick ups, trucks and busses. These tools have up to five different sizes, which make them more attractive than buying several wrenches. Cross wrenches are designed to assure continuous use.

C20 y C18 se utilizan para extraer e instalar tuercas para automóviles, camionetas y pick-ups. El resto se utilizan para camiones, trailers y microbuses.

C20 and C18 models are used to remove off nuts from cars and pick-ups. The rest of the models are used to remove nuts and studs off trucks and busses.

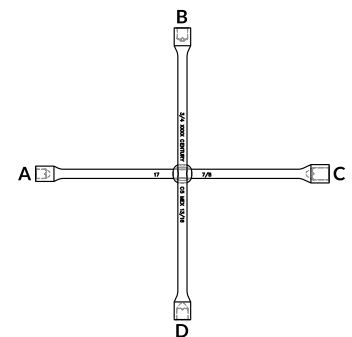

() Equivalencias / Equivalencies

insq= Cuadro Interior en hexágono
/ hexagonal Inside Square

Outsq= Cuadro exterior
/ Outside square

● Medidas especiales
(lote mínimo 200 piezas)
/ Special requirements
(minimum batch 200 pieces)



D4



D5

LLAVES DE ARTILLERÍA MILIMÉTRICAS / Milimetric single and double ended wrenches

Las llaves de artillería son herramientas que tienen una o dos bocas hexagonales de diferentes medidas, algunas cuentan con un cuadro interior para extraer capuchones. El maneral se vende por separado.

Wrenches have one or two hexagonal ends of different sizes, some have an internal square to remove studs. Handle bars are sold separately. D1 and D2 are used to remove nuts off cars and pick-ups. The other models are used to remove the nuts of the truck, and buses.

La D1 y D2 se utilizan para extraer tuercas de llantas para automóvil y camioneta. El resto de las llaves se utilizan para extraer las llantas de camiones, autobuses y trailers.

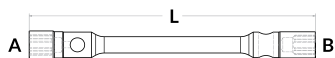

() Equivalencias / Equivalencies

insq= Cuadro Interior en hexágono
/ hexagonal Inside Square

● Medidas especiales
(lote mínimo 100 piezas)
/ Special requirements
(minimum batch 100 pieces)

Modelo Model	Hexágono A	Hexágono B	Interior Insq	Longitud	Peso Kg	Maneral	Empaque
D1	19 mm (3/4")	17mm	-	152 mm	0.5	M10	24
● D24	33 mm	24 mm (15/16")	-	432 mm	2.4	M3	10
● D27P	27 mm (1-1/16")	-	-	432 mm	2.4	M2	10
● D30M	30 mm (1-3/16")	27 mm (1-1/16")	-	432 mm	2.4	M3	10
D30P	31 mm	-	-	457 mm	2.8	M2	10
D31P	31 mm	-	-	458 mm	2.9	M2	10
D32P	32 mm (1-1/4")	-	-	457 mm	2.9	M2	10
D33	33 mm	27 mm (1-1/16")	-	432 mm	2.4	M3	10
D33D	33 mm	32 mm (1-1/4") Insq = 21 mm	-	457 mm	3.2	M2	10
D33P	33 mm	-	-	457 mm	6.4	M2	10
● D32MP	32 mm (1-1/4")	30 mm (1-3/16")	-	458 mm	3.0	M2	10
● D32E	33 mm	32 mm (1-1/4")	-	432 mm	2.6	M3	10
● D34	32 mm (1-1/4")	27 mm (1-1/16")	-	432 mm	2.4	M3	10
● D34C	32 mm (1-1/4") Insq = 13/16"	27 mm (1-1/16")	-	432 mm	2.4	M3	10
● D33MP	33 mm	30 mm (1-3/16")	-	458 mm	3.2	M2	10
● D35	35 mm (1-3/8")	-	17 mm	458 mm	3.2	M2	10
● D35E	35 mm (1-3/8")	32 mm (1-1/4") Insq = 17 mm	-	457 mm	3.5	M2	10
● D36	35 mm (1-3/8")	-	22 mm	458 mm	3.2	M2	10
● D40	35 mm (1-3/8")	33 mm	-	458 mm	3.2	M2	10
D41	41 mm (1-5/8")	-	21 mm	432 mm	3.0	M2	10
D41H	41 mm (1-5/8")	-	20 mm	432 mm	3.0	M2	10
● D41N	41 mm (1-5/8")	-	21 mm	432 mm	3.0	M2	10
D41D	41 mm (1-5/8")	33 mm Insq = 21 mm	-	458 mm	3.2	M2	10
D41C	41 mm (1-5/8")	-	13/16"	458 mm	3.0	M2	10
D41E	41 mm (1-5/8")	38 mm (1-1/2") Insq = 21 mm	-	458 mm	3.5	M2	10
● D40C	35 mm (1-3/8")	33 mm Insq = 13/16"	-	458 mm	3.2	M2	10
● D59	35 mm (1-3/8")	32 mm	-	458 mm	3.2	M2	10
● D59C	35 mm (1-3/8")	32 mm Insq = 13/16"	-	458 mm	3.2	M2	10
● D36P	36 mm	-	-	458 mm	3.0	M2	10
● D57C	38 mm (1-1/2")	31 mm Insq = 13/16"	-	458 mm	3.4	M2	10
● D58C	38 mm (1-1/2")	32 mm Insq = 13/16"	-	458 mm	3.4	M2	10
D33C	41 mm (1-5/8")	33 mm Insq = 13/16"	-	458 mm	3.1	M2	10
D42	41 mm (1-5/8")	-	19 mm (3/4")	458 mm	3.1	M2	10

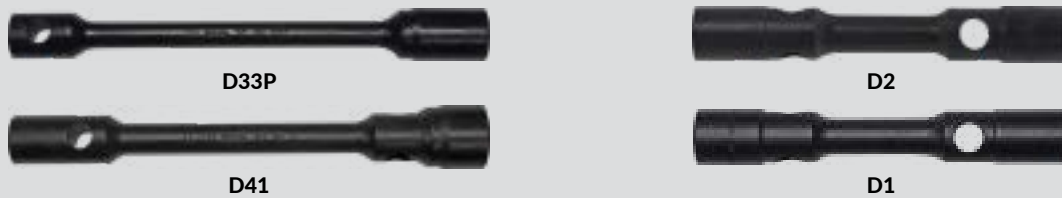

Llaves de artillería en medida estándar (pulgadas)

/ Standard single and double ended wrenches

Modelo Model	Hexágono A	Hexágono B	Interior Insq	Longitud ←→	Peso Kg	Maneral 	Empaque 
D2	13/16"	3/4" (19 mm)	-	256 mm	0.81	M10	30
D2L	13/16"	3/4" (19 mm)	-	432 mm	1.9	M1	12
D3	1-1/16" (27 mm)	7/8" (22 mm)	-	432 mm	2.2	M3	12
D4	7/8" (22 mm)	13/16"	-	432 mm	1.8	M1	12
D5	15/16"	7/8" (22 mm)	-	432 mm	1.8	M1	12
D6	1-1/16" (27 mm)	1"	-	432 mm	2.3	M3	12
D7	1-1/8"	7/8" (22 mm)	-	432 mm	2.2	M3	12
D8	1-1/8"	1"	-	432 mm	2.4	M3	12
● D25	1-1/8"	1-1/16"	-	432 mm	2.3	M3	10
● D29	1-1/4" (32mm)	1-1/8"	-	432 mm	2.5	M3	10
● D29C	1-1/4" (32mm) Insq=13/16"	1-1/8"	-	432 mm	2.5	M3	10
D9	1-1/4" (32mm)	1-1/16" (27 mm)	-	432 mm	2.5	M3	10
● D9C	1-1/4" (32mm) Insq=13/16"	1-1/16" (27 mm)	-	432 mm	2.5	M3	10
● D9P	1-1/4" (32mm)	-	-	432 mm	2.6	M2	10
D10	1-1/2" (38 mm)	-	13/16"	458 mm	3.2	M2	10
● D10F	1-1/2" (38 mm)	-	22 mm (7/8")	458 mm	3.2	M2	10
● D38	1-1/2" (38 mm)	1-1/8"	-	458 mm	3.2	M2	10
● D38C	1-1/2" (38 mm)	1-1/8" Insq=13/16"	-	458 mm	3.2	M2	10
● D55D	1-1/2" (38 mm)	1-1/4" (32mm) Insq=21 mm	-	458 mm	3.3	M2	10
D55C	1-1/2" (38 mm)	1-1/4" (32mm) Insq=13/16"	-	458 mm	3.3	M2	10
D56C	1-1/2" (38 mm)	33 mm Insq=13/16"	-	458 mm	3.3	M2	10
D56D	1-1/2" (38 mm)	33 mm Insq=21 mm	-	458 mm	3.3	M2	10
● D56	1-1/2" (38 mm)	33 mm	-	458 mm	3.3	M2	10

Federal GGG-W-644

() Equivalencias / Equivalencies

insq= Cuadro Interior en hexágono
/ hexagonal Inside Square

- Medidas especiales
(lote mínimo 100 piezas)
/ Special requirements
(minimum batch 100 pieces)



M2



M3

MANERALES DE ALTA RESISTENCIA AL TORQUE / HEAVY DUTY HANDLELS

Llaves en "L" / "L" shape wrenches

Herramientas para retirar o colocar tuercas en las ruedas de automóvil y camioneta.

Easy-to-use tool to remove wheel nuts off cars and trucks.

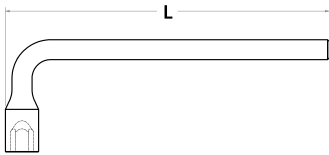

Modelo Model	Hexágono ⬠	Longitud ┈┈┈	Peso Kg	Empaque 📦
L1	17 mm	290 mm	0.76	10
L2	3/4" (19mm)	290 mm	0.79	10
L3	13/16"	290 mm	0.76	10

Manerales para llaves de artillería / Wrench handle bars

Estas barras se insertan en uno de los barrenos de las llaves de artillería para poder aplicar una palanca.

These handle bars are inserted within one of the wrenches holes to apply a leverage force.



Modelo Model	Hexágono ⬠	Longitud ┈┈┈	Peso Kg	Empaque 📦
M10	5/8"	378 mm	0.57	24 o 30
M1	11/16"	500 mm	0.9	30
M2	59/64"	397 mm	1.3	20
M2L	59/64"	497 mm	1.6	20
M3	27/32"	448 mm	1.3	20
M4	11/16"	497 mm	1.6	20
M5	27/32"	448 mm	1.3	20

Manerales con cuadro exterior / External square handle

Modelo Model	Sección	Cuadro exterior	Longitud ┈┈┈	Peso Kg	Empaque 📦
M4	11/16"	1/2 "	384 mm	0.7	5
M5	1"	3/4 "	500 mm	1.9	5



M2L



Maneral corredizo

/ Sliding T-bar

Modelo Model	Sección Ø	Cuadro exterior Outsq	Longitud	Peso Kg	Empaque
MC1	59/64"	1"	628 mm	2.5	6
MC2	59/64"	3/4"	500 mm	2.0	6

Son barras versátiles que pueden ser utilizadas para hacer girar cualquier tipo de dado.

These are versatile bars that can be used to rotate any socket.

Maneral en L

/ L handle

Modelo Model	Sección Ø	Cuadro exterior Outsq	Longitud	Peso Kg	Empaque
ML1	1"	1"	660 mm	3.0	5
ML2	1"	3/4"	476 mm	2.1	5
ML2L	1"	3/4"	673 mm	2.9	5
ML3	5/8"	1/2"	284 mm	0.5	5
ML4	1-1/4"	1-1/2"	676 mm	5.4	5

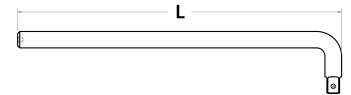

Maneral articulado

/ Flexible handle

Modelo Model	Sección Ø	Cuadro exterior Outsq	Longitud	Peso Kg	Empaque
MA1	11/16"	1/2"	444 mm	0.90	5
MA1L	11/16"	1/2"	600 mm	1.16	5
MA2	1"	3/4"	470 mm	1.90	5
MA3	1"	1"	538 mm	2.80	5

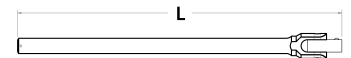

Kit de repuesto para maneral articulado de 1/2"

/ Articulated replacement kit for flexible handle 1/2" DR

Modelo Model	Cuadro Sq	Empaque
MAR1	1/2"	10

Incluye cuadro de mando de 1/2", resorte, tornillo y balín / Includes drive square 1/2", spring, screw and ball.





HERRAMIENTAS DE ALTA RESISTENCIA PARA DESMONTAR Y MONTAR LLANTAS / HEAVY-DUTY IMPACT BEAD BREAKERS

Espátulas / Lock ring and Bead Breakers

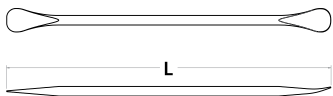

E2

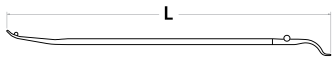

E5

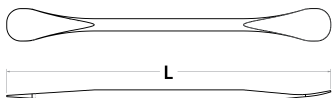

E6

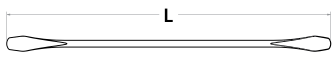

E8

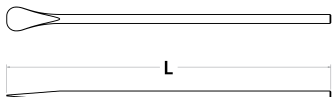

ME1, ME2

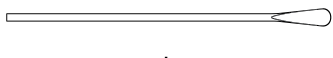

ME3

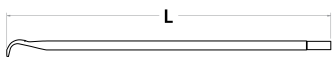

Modelo Model		Sección Ø	Longitud	Peso Kg	Empaque
E1	DE UÑA	11/16"	660 mm	1.2	20
E2	DOBLE CUCHARA CORTA	3/4"	635 mm	1.4	15
E3	DOBLE CUCHARA LARGA	3/4"	760 mm	1.7	15
E4	CABEZA DE GANSO	1"	867 mm	3.3	5
E5	SOPORTE PARA RIN	3/4"	940 mm	2.1	10
E5S	SOPORTE PARA RIN SIN TOPE	3/4"	940 mm	2.0	10
E6	DOBLE CUCHARA PARA MOTO	5/8"	380 mm	0.6	20
E7	DE UÑA PARA MOTO	5/8"	380 mm	0.55	20
E8	DOBLE CUCHARA	3/4"	900 mm	1.9	15
ME1	MANERAL Y ESPÁTULA	11/16"	622 mm	1.19	15
ME2	MANERAL Y ESPÁTULA PLANA	11/16"	760 mm	1.45	15
ME3	MANERAL Y ESPÁTULA CURVA	11/16"	760 mm	1.45	15



ME1



E3



Marros talache y barra de golpe

/ Bead breaking hammers and heavy duty beadbreaker slide hammer bars for tires

Modelo Model		Longitud ┌───┐	Peso Kg	Empaque 📦
TG11EH	MARRO C/MANGO MADERA	830 mm	4.0	1
T11EH	MARRO C/MANGO FIBRA DE VIDRIO	890 mm	4.6	1
T26B	BARRA DE GOLPE	1200 mm	10.8	1

Este marro sirve para despegar las cejas de las llantas de camión. Está disponible con mango de madera y fibra de vidrio que protege al usuario.

Tire bead breaking hammer, fiberglass handle and wood. Heavy duty impact bead breaker



Separador de cejas, herramienta para montar y desmontar llantas sin cámara

/ Tire changing tool and bead keeper

Modelo Model		Longitud ┌───┐	Peso Kg	Empaque 📦
TN10	DESMONTADORA	1400 mm	8.0	3
TN11	MONTADORA	1180 mm	2.2	3
SC	SEPARADOR DE CEJA	160 mm	0.2	3

Herramientas para montar y desmontar las llantas de camiones de 17.50" hasta 24.50" para la mayoría de las llantas radiales sin cámara. Elimina la necesidad de levantar la llanta para quitar la cámara.

Demounts tires 17.50" to 24.50" including most radial tires. Eliminate the need to lift the rim to remove the bottom bead.

Multiplicador de torque

/ torque multiplier

Modelo Model	Torque NM	Fuerza kgf	Entrada ■	Peso Weight
MTO1 5200	5200	530	1"	5.54 kg
MTO2 7800	7800	795	1"	7.29 kg

Se requiere extensión EX4P / Requiere extension EX4P



GHC12



GHC20



HERRAMIENTAS DE ALTA RESISTENCIA PARA EL USO CONSTANTE
/ HEAVY DUTY TOOLS

Gatos hidráulicos de botella para trabajo pesado
/ Heavy duty bottle jack

100% Reparable. Pistón y vástago con tratamiento térmico especial antidesgaste y corrosión. Empaques del cilindro de levante de alto rendimiento. La cabeza del tornillo es una extensión con rebordes piramidales que reducen al mínimo la posibilidad del deslizamiento de la carga. Cumple con la NOM-114-SCFI. Puede ser utilizado en un ángulo vertical y una posición horizontal.

100% Repairable. Piston and spindle with special heat treatment and corrosion wear resistance. High-performance gaskets for the lifting cylinder. Head of the extension screw with pyramidal edge that helps reducing a possible load sliding injection and return valve integrated into the jack's base. It meets mexicans standard NOM-114-SCFI. Can be used in the vertical angled or horizontal position.

Modelo Model	Capacidad Capacity	Altura Mínima Minimum Height	Recorrido Hidráulico Hydraulic Stroke	Recorrido Extensible Extension Sc	Altura Total Total High	Peso Weight
GHC12	12 tons	230 mm	140 mm	90 mm	450 mm	7.7 kg
GHC20	20 tons	242 mm	190 mm	-	470 mm	10.9 kg

Pistolas neumáticas
/ Heavy duty air neumatic wrenches

Modelo Model	Mando	Toma de aire	Velocidad max RPM	Fuerza N-m	Peso Weight
PNP 2500	1"	1/2"	4000	2500	14.5 kg
PNT 2000	3/4"	1/2"	6000	2000	8.2 kg
PNM 850	1/2"	1/4"	7600	850	3.0 kg

Garantía limitada / Limited warranty.



PNM 850



PNT 2000



PNP 2500



JUEGOS PARA EL CAMBIO CONSTANTE DE RUEDAS / HEAVY DUTY KITS.

Juegos de dados de impacto hexagonales con cuadro de 1/2" para cambio de ruedas con adaptador y nudo

/ 6 point wheel service impact socket 1/2" DR, with adapter and universal join set

SJ1	Modelo Model	Hexágono II	Hexágono mm	Mando ■	A (mm)	B (mm)	L (mm)	Forma Shape	Juego / set 7 pzas
	S17		17 mm	1/2"	26	26	75	I	1
	S19	3/4"	19 mm	1/2"	28	28	75	I	1
	S21	13/16"		1/2"	30	30	75	I	1
	S22	7/8"	22 mm	1/2"	32	32	75	I	1
	A2	1/2" Sq ex		3/4"	-	-	58	-	1
	NUD3	1-1/2"		1/2"	-	-	75	-	1
	EX3	1/2" Sq ex		1/2"	25	17	75	-	1

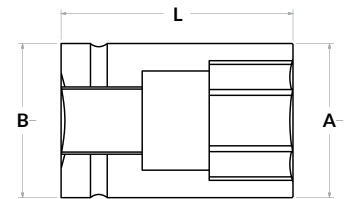

Forma I / Shape I

Juegos de dados de impacto hexagonales con cuadro de 3/4" para cambio de ruedas con adaptador y nudo

/ 6 point wheel service impact socket 3/4" DR, with adapter and universal join set

SJ2	Modelo Model	Hexágono II	Hexágono mm	Mando ■	A (mm)	B (mm)	L (mm)	Forma Shape	Juego / set 7 pzas
	S21T	13/16"		3/4"	35	44	78	II	1
	S22T	7/8"	22 mm	3/4"	36	44	78	II	1
	S24T	15/16"		3/4"	36	44	78	II	1
	S25T	1"	25 mm	3/4"	41	41	78	I	1
	A1	3/4" Sq ex		1/2"	-	-	48	-	1
	NUD4	3/4"		3/4"	-	-	108	-	1
	EX4T	3/4" Sq ex		3/4"	44	25	100	-	1

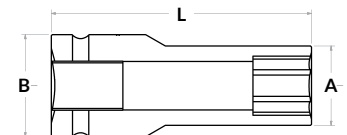

Forma II / Shape II

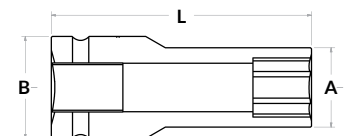

Forma IV / Shape IV

Juegos de dados de impacto hexagonales con cuadro de 3/4" para cambio de ruedas con adaptador y nudo

/ 6 point wheel service impact socket 3/4" DR, with adapter and universal join set

SJ3	Modelo Model	Hexágono II	Hexágono mm	Mando ■	A (mm)	B (mm)	L (mm)	Forma Shape	Juego / set 7 pzas
	S27T	1-1/16"	27 mm	3/4"	42	42	78	I	1
	S24T	15/16"	24 mm	3/4"	39	44	78	I	1
	S30T	1-3/16"	30 mm	3/4"	46	44	78	IV	1
	S32T	1-1/4"	32mm	3/4"	46	44	78	I	1
	*A4	3/4" Sq ex		1"	-	-	70	-	1
	NUD4	3/4"		3/4"	-	-	108	-	1
	EX4T	3/4" Sq ex		3/4"	44	25	100	-	1

Modelo equivalente
/ Equivalent model

A: Diámetro exterior en Hexágono
/ Hexagonal external diameter

B: Diámetro exterior en cuadro
/ Squared external diameter

L: Longitud total / Total length



SJ4



SJD



SJDT

Juegos de dados de impacto hexagonales con cuadro de 1" para cambio de ruedas
/ 6 point wheel service impact socket 1" DR set

Este juego puede ser utilizado en el cambio de ruedas de tractocamiones.

This set can be used in truck wheel service.

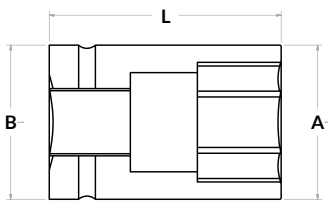

Forma I / Shape I

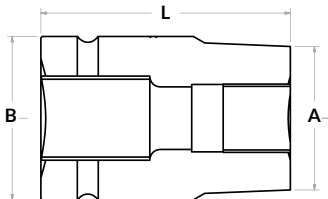

Forma V / Shape V



Forma II / Shape II

SJ4	Modelo Model	Hexágono II	Hexágono mm	Mando	A (mm)	B (mm)	L (mm)	Forma Shape	Juego / set 7 pzas
	S1	1-1/2"	38 mm	1"	60	60	86	I	1
	S2	Insq:13/16"		1"	46	50	75	V	1
	S5	1-1/4"	32mm	1"	52	54	86	II	1
	S33		33 mm	1"	54	52	86	II	1
	S41		41 mm	1"	61	54	86	IV	1
	D20	1-1/2"		-	-	-	160	-	1
	D13	1-1/8"		-	-	-	76	-	1

SJ4B	Modelo Model	Hexágono II	Hexágono mm	Mando	A (mm)	B (mm)	L (mm)	Forma Shape	Juego / set 4 pzas
	S1, S2, S33, D13	Aplican los mismos valores	Aplican los mismos valores	Aplican los mismos valores	Aplican los mismos valores	Aplican los mismos valores	Aplican los mismos valores	Aplican los mismos valores	1

Juego de dados de impacto hexagonales de pared delgada para rin deportivo con cuadro de 1/2"
/ 6 point extra thin wall impact socket 1/2" DR set

SJD	Modelo Model	Hexágono II	Hexágono mm	Mando	A (mm)	B (mm)	L (mm)	Forma Shape	Juego / set 4 pzas
	SD17		17 mm	1/2"	25	25	75	I	1
	SD19	3/4"	19 mm	1/2"	27	27	75	I	1
	SD21	13/16"		1/2"	29	29	75	I	1
	SD22	7/8"	22 mm	1/2"	30	30	75	I	1

Juego de dados de impacto hexagonales de pared delgada para rin deportivo con cuadro de 3/4"
/ 6 point extra thin wall impact socket 3/4" DR set

SJDT	Modelo Model	Hexágono II	Hexágono mm	Mando	A (mm)	B (mm)	L (mm)	Forma Shape	Juego / set 2 pzas
	SD19T	3/4"	19 mm	3/4"	28	38	75	II	1
	SD21T	13/16"		3/4"	29	38	75	II	1

Juego de 2 dados dobles de impacto hexagonales fliper con cuadro de 1/2" y extensión
/ 6 point extra thin wall impact socket with 2 end 1/2" DR and extensión set

SJEFD	Modelo Model	Hexágono mm	Hexágono mm	Mando	A (mm)	B (mm)	L (mm)	Forma Shape	Juego / set 3 pzas
	FD1	17mm	19mm	1/2"	25	27	76	0.12	1
	FD2	19mm	21mm	1/2"	27	29	76	0.13	1
	EX3	-		1/2"	-	-	75	0.19	1

Garantía limitada / Limited warranty / Incluye estuche / case included



SJEFD



SJRT



EJ1

Juego removedor de tuercas y seguros (9 piezas)

/ Lug nut remover socket set (9 Pieces)

SJRT	Modelo Model	A (mm)	B (mm)	L (mm)	Peso Kg	Juego / set 9 pzas
	RT17	17	23	55	0.12	1
	RT18	18.5	25	55	0.12	1
	RT20	20	26	55	0.12	1
	RT21	21.5	28	55	0.12	1
	RT23	23	30	55	0.13	1
	RT24	24.5	30.5	55	0.13	1
	RT26	26	32	55	0.13	1
	RT27	27.5	33	55	0.13	1
	RSTR	1/2"	Insq: 1/2"	50	0.12	1

Garantía limitada / Limited warranty / Incluye estuche / case included

Juego de dados utilizados para extraer tuercas barridas y birlos de seguridad. Se utiliza con maneral con cuadro de 1/2" o con pistola neumática.

Socket set remove stripped studs or damaged lug nuts or locking wheel nuts if the key has been misplaced.

Juego tuercas de seguridad

/ Heavy duty wheel lock set

SJTS2	Modelo Model	Hexágono	Peso Gr	Peso total del set Kg	Juego / set 14 pzas
	TS2	33 mm	270	3.16	12
	DS2	33 mm	270	3.16	2

Incluye 12 tuercas de seguridad (TS) y dos dados de seguridad (DS) / Includes 12 nuts and 2 keys.



SJTS2

Juego tuercas extractor

/ Impact inner cap nut remover kit

SJTE	Modelo Model	Hexágono exterior A	Extractor B	Longitud	Peso Kg	Juego / set 6 pzas
	ET	1-1/2"	1-1/8"	30 mm	0.13	1
	D5S	-	-	75 mm	0.82	5

Se surte 1 tuerca y 1 herramienta /



SJTE

Juego desmontador

/ Dismount set

SJ1	Modelo Model	Longitud	Peso Kg	Juego / set 3 pzas
	TN10	DESMONTADORA	1400 mm	8.0
	TN11	MONTADORA	1180 mm	2.2
	SC	SEPARADOR DE CEJA	160 mm	0.2



LLAVES PARA EXTRAER CENTROS DE MAZA / TRUCK SPINDLE NUT WRENCHES

Dados para centro de maza octagonales y hexagonales / Truck axel nut sockets 8pt and 6pt

Sirve para montar y desmontar la tuerca del balero.

Los centros de maza están diseñados para utilizarse con manerales, no usa pistola neumática.

*It is used to remove and install the bearing nut.
These truck axel sockets are designed for use with breaker bars or ratched handles, but not with power impact drivers.*

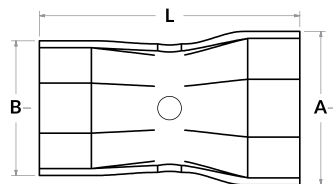
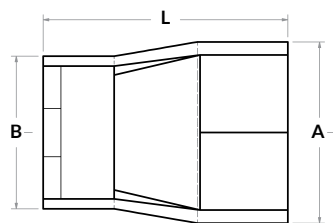

Forma VII / Shape VII

Modelo Model	Hexágono	mm	Cuadro	A (")	B (")	L (")	Forma Shape	Peso Kg	Empaque
OS57	2-1/4"	57	3/4"	2.696	2.375	3.790	VI	0.90	10
OS60	2-3/8"	60	3/4"	2.821	2.375	3.790	VI	0.7	10
OS63	2-1/2"	63	3/4"	2.946	2.875	3.790	VI	1.1	10
OS65	2-9/16"	65	3/4"	3.008	2.875	3.790	VI	1.1	10
OS66	2-5/8"	66	3/4"	3.071	2.875	3.790	VI	1.2	10
OS69	2-3/4"	69	3/4"	3.196	2.875	3.790	VI	1.2	10
OS73	2-7/8"	73	3/4"	3.321	2.875	3.790	VI	1.2	10
OS76	3"	76	3/4"	3.472	3.460	3.790	VI	1.4	10
OS83	3-1/4"	83	3/4"	3.722	3.500	3.790	VI	1.5	10
OS88	3-1/2"	88	3/4"	3.968	3.500	3.790	VI	1.6	5
OS95	3-3/4"	95	3/4"	4.228	4.500	3.790	VI	2.0	5
OS98	3-7/8"	98	3/4"	4.347	4.500	3.790	VI	1.6	5
OS102	4"	102	3/4"	4.548	4.500	3.790	VI	2.1	5
OS105	4-1/8"	105	3/4"	4.660	4.500	3.790	VI	2.1	5
OS111	4-3/8"	111	3/4"	4.911	4.500	3.790	VI	2.2	5
OS124	4-7/8"	124	3/4"	5.412	4.500	3.790	VI	2.3	5
Octágono									
OC65	2-9/16"	65	3/4"	3.008	2.875	4.055	VI	1.0	10
OC83	3-1/4"	83	3/4"	3.722	3.500	4.055	VI	1.4	10
OC88	3-1/2"	88	3/4"	3.968	3.500	3.900	VI	1.6	10
OC95	3-3/4"	95	3/4"	4.228	4.500	3.900	VI	1.9	5
OC97	3-13/16"	97	3/4"	4.325	4.500	3.790	VI	2.0	5
OC98	3-7/8"	98	3/4"	4.347	4.500	3.790	VI	2.0	-
OC105	4-1/8"	105	3/4"	4.649	4.500	3.900	VI	2.1	5
OC111	4-3/8"	111	3/4"	4.911	4.500	4.055	VI	2.2	5
OC114	4-1/2"	114	3/4"	5.036	4.500	3.790	VI	2.2	5
OC120	4-3/4"	120	3/4"	5.210	4.500	3.900	VI	2.2	5
OC123	4-13/16"	123	3/4"	5.264	4.500	3.900	VI	2.2	5
OC124	4-7/8"	124	3/4"	5.389	4.500	4.055	VI	2.2	5

Utiliza maneral en "L" (ML2) ó maneral corredizo (MC2) / Use L handle (ML2) or Sliding T-Bar (MC2)

No utilizar pistola neumática / Shall not be used with impact tools

* Para remolque trasero trailer SUDISA / Rear Two trailer SUDISA

Dado doble octagonal / Axle nut sockets 8pt double

Multibarreno, sirve para contar el número de vueltas al realizar la maniobra.

Multiblast-hole, servers to shorten number of turns in the manuevuer.

Modelo Model	Octágono pulgadas		Maneral	A (")	B (")	L (")	Forma Shape	Peso Kg	Empaque
DOC95	3-3/4" x 3-1/4"	95x83	M10	4.2	3.7	7.0	VII	2.0	5
*DOC98	3-3/4" x 3-3/8"	95x86	M10	4.2	3.9	7.0	VII	2.0	5
*DOC99	3-7/8" x 3-3/8"	98x86	M10	4.4	3.9	7.0	VII	2.0	5

Utiliza maneral M10 / Use handle M10



A1 -4

ACCESORIOS DE ALTA RESISTENCIA
/ HEAVY DUTY ACCESSORIES

Dado de torque de 3/4" para suspensión Hendrickson

/ Hendrickson suspension socket 3/4" DR.

Modelo Model	Boca ✳	Longitud	Mando	Peso Kg	Empaque
SET19	E20	53.40 mm	3/4"	0.3	5

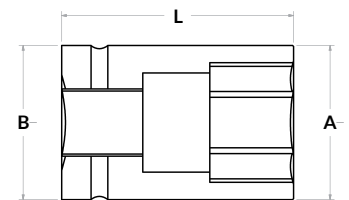

Forma I / Shape I

Llave para suspensión Hendrickson

/ Hendrickson suspension wrench

Modelo Model	Hexágono	Longitud	Peso Kg	Maneral	Empaque
DS10	1-1/2"	116 mm	1.10	M2	5

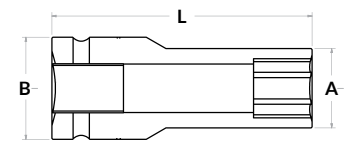

Forma IV / Shape IV

Esta llave sirve para el montaje y desmontaje de suspensiones Hendrickson. Además, se utiliza para desmontar tuercas que están muy apretadas, golpeando su extremo.

This tool is used to dismount Hendrickson suspension. Also can be used to unlight nuts hitting its external face.



SET 19



A1 -4

Adaptadores de impacto

/ Impact adapters

Los adaptadores de impacto están diseñados para adecuar las medidas del cuadro de mando, "adaptando" la medida a una mayor o menor dimensión. Pueden utilizarse indistintamente con herramientas de impacto o manuales. Los modelos A2, A4 y A5 no están garantizados.

The adapters are designed to fit square drive sizes "adapting" it to a bigger or smaller size. They can be used indiscriminately with impact or manual tools. A2, A4 y A5 are not warranted.

Modelo Model	Punta Hexagonal	Mando	Longitud	Peso Kg	Empaque
A1	3/4"	1/2"	50 mm	0.17	10
A2	1/2"	3/4"	59 mm	0.30	20
A3	1"	3/4"	66 mm	0.45	10
A4	3/4"	1"	74 mm	0.50	20
A5	1"	1-1/2"	105 mm	2.35	10
A6	1-1/2"	1"	89 mm	1.30	10
A7	2-1/2"	1-1/2"	124 mm	4.10	5
A8	1-1/2"	2-1/2"	142 mm	6.30	5

Adaptadores con perno y liga

/ Adapters with pin and o-ring

Modelo Model	Punta Hexagonal	Mando	Longitud	Peso Kg	Empaque
A1	3/4"	1/2"	50 mm	0.17	10
A3	1"	3/4"	66 mm	0.45	10

Estos adaptadores tienen un mango articulado que se ensambla en las extensiones o en los dados de impacto, permitiendo el alcance de tuercas y tornillos en sitios de difícil acceso. Pueden utilizarse también con cualquier maneral con cuadro exterior.

This adapters create a jointed connection in the drive line that permits the driving angle to change. They can be used with any outside square handles.

Extensiones con perno y liga

/ Extensions with pin and o-ring

Modelo Model	Entrada / Salida	Longitud	Peso Kg	Empaque	
EX3	1/2"	76 mm	3"	0.15	10
EXT	3/4"	76 mm	8"	1.50	10
EX7P	1"	178 mm	7"	1.50	10
EX12P	1"	305 mm	12"	2.00	10

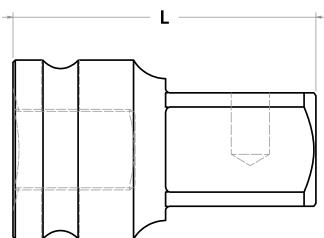

Accesorios de alto impacto con cuadro de 1/2"

/ Heavy duty extension 1/2" DR

Modelo Model	Entrada / Salida	Longitud		Peso Kg	Empaque
EX3	1/2"	76 mm	3"	0.15	10
EX6	1/2"	152 mm	6"	0.30	10
EX10	1/2"	254 mm	10"	0.44	10

Extensiones de impacto con cuadro de 3/4"

/ Heavy duty extension 3/4" DR

Modelo Model	Entrada/ Salida	Longitud		Peso Kg	Empaque
EX4T	3/4"	102 mm	4"	0.60	10
EX5T	3/4"	127 mm	5"	0.70	10
EX6T	3/4"	152 mm	6"	0.78	10
EX10T	3/4"	254 mm	10"	1.20	10



EX

Extensiones de impacto con cuadro de 1"

/ Heavy duty extension 1" DR

Modelo Model	Entrada / Salida	Longitud		Peso Kg	Empaque
EX4P	1"	102 mm	4"	1.00	10
EX7P	1"	178 mm	7"	1.50	10
EX12P	1"	305 mm	12"	2.00	10

LIGA / O - ring

Modelo Model	Mando	Diámetro (mm)	Grosor (mm)	Empaque
OR19	1/2"	19	4	20
OR24	1/2"	24	4	20
OR36	3/4"	36	5	20
OR46	3/4"	46	5	20
OR44	1"	44	5.7	20
OR75	1"	75	7	20

Perno candado / Pin

Modelo Model	Mando	Diámetro (mm)	Grosor (mm)	Empaque
LR20	1/2"	20	3	20
LR25	1/2"	25	3	20
LR35	3/4"	35	4	20
LR45	3/4"	45	4	20
LR455	1"	45	5	20
LR75	1"	75	5	20



Adaptadores de impacto articulados

/ Heavy duty adapter

Modelo Model	Mando ■	Cuadro exterior Outsq	Diámetro Diameter	Longitud ←→	Peso Kg	Empaque 📦
AA1	1/2"	1/2"	1.250"	3-1/4"	0.40	10
AA2	3/4"	3/4"	1.500"	4-1/8"	0.60	10
AA3	3/4"	1"	2.000"	4-5/8"	1.15	10
AA4	?					

Nudo universal de impacto articulado

/ Universal-joint

Modelo Model	Mando ■	Diámetro exterior		Peso Kg	Empaque 📦
SAU3	1/2"	30	63	0.15	10
SAU4	3/4"	44	105	0.70	10
SAU5	1"	54	130	1.60	10

Las extensiones de impacto son para ampliar la longitud de mando. También pueden utilizarse con cualquier herramienta de impacto o manual.

The extensions are used to increase drive length. Also can be used with all manual or impact tools.

Nudo universal doble articulación

/ Universal Joint

Modelo Model	Mando ■	Diámetro (mm)	Peso Kg	Empaque 📦
NUD3	1/2"	75	0.16	10
NUD4	3/4"	108	0.59	10
NUD5	1"	143	0.70	10





**BIRLOS Y
SUJECIONES
DE ALTA
RESISTENCIA**

***Heavy
duty
fasteners***

Nomenclatura del producto

/ Product Nomenclature

Con la finalidad de describir nuestros productos, les hemos designado un número de parte de acuerdo a la nomenclatura y codificación descritas a continuación.

In order to describe our products we've designed a number of part according to the nomenclature and coding described below.

BM-I-02880 D/I

D - Derecho / right
I - Izquierdo / left

L - Longitud del producto en milésimas de pulgada / Product length in mils

Diámetro del producto / Product diameter

I 3/4"
K 7/8"
M 1"
P 1-1/8"
MM 20mm - 22mm

Descripción básica del producto / Basic description of the product

- BTI Birlo Tope Intermedio / double ended clipped stud collar shoulder type
- BTM Birlo Tope Intermedio Moleteado / double ended clipped knurled stud collar shoulder type
- BM- Birlo Maza Moleteado / rounded head stud with serrated body type
- BML Birlo Maza Moleteado Largo / rounded head stud with large serrated body type
- BMA Birlo Maza Aluminio / wedged head stud
- CB Capuchón para Birlo / inner cap nut for stud
- TC Tuerca para Capuchón / cap nut wheel heavy duty trucks
- TF Tuerca milimétrica / millimetric nut

Esquema de medidas

/ Outline Measurement

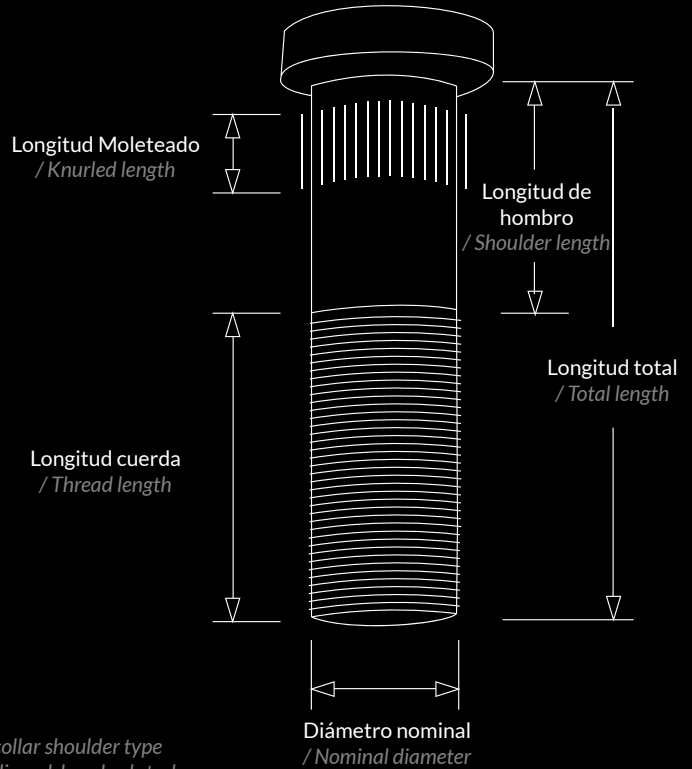

Tipos de cabeza

/ Head Type



Cabeza D
/ D head type



Cabeza plana
/ Clipped D head type



Cabeza Normal
/ Rounded head type



Cabeza Scania
/ Scania head type



Cabeza Rin Aluminio
/ Wedged head type

BIRLOS MILIMÉTRICOS / METRIC STUDS

Imágenes en escala
/ Scale image

BM-M20-00046 D/I

Rueda / wheel:
Trasera / rear / Delantera / Front Wheel

Aplicación / application:
HINO Camión Clase 360 Modelo 514 6716 816 híbrido
/ HINO trucks Class 360 Model 514 6716 816 híbrid

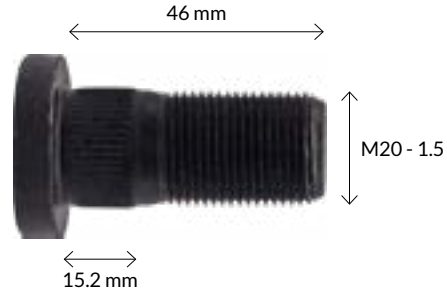

BM-M20-00053 D/I

Rueda / wheel:
Delantera / Front Wheel

Aplicación / application:
Isuzu camión Clase 4 Elf 400, 500, 600, 700
/ Isuzu truck Class for model Elf 400, 500, 600, 700



BM-M20-00067 D/I

Rueda / wheel:
Trasera / rear

Aplicación / application:
Isuzu camión Clase 4 Elf 400, 500, 600, 700
/ Isuzu truck Class for model Elf 400, 500, 600, 700



BM-M22-00094

Rueda / wheel:
Trasera / rear

Otros / others:
1 9737 2 99-074

Aplicación / application:
Kenworth Dina 9400 Serie 651

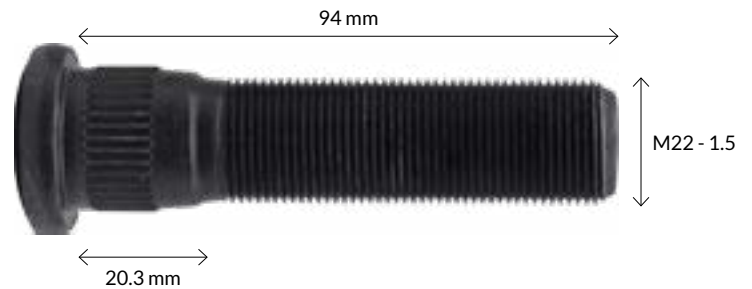

BM-M22-00100

Rueda / wheel:
Trasera / rear

Otros / others:
1 9709 R 2 99-067 3 50-082 4 8981 6 M-3666.

Aplicación / application:
Eje Rockwell / Rockwell axis

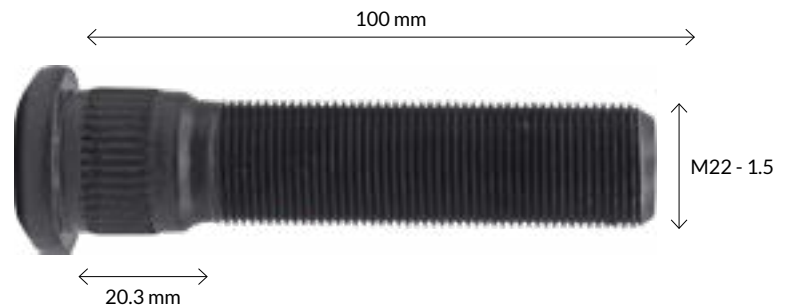

BM-M22-00106

Rueda / wheel:
Trasera / rear

Otros / others:
6 M-3668

Aplicación / application:
Kenworth Dina 9400 Serie 651

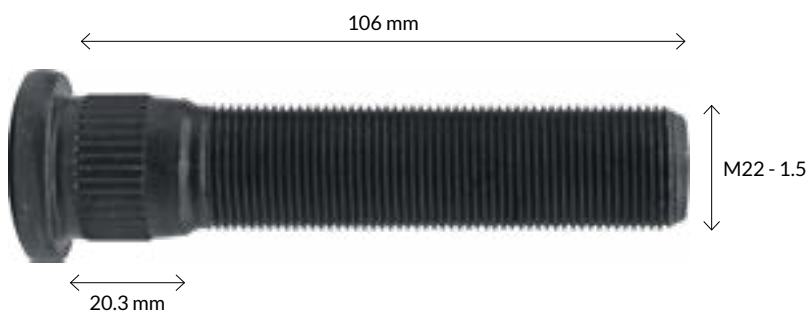
BM-M22-00114

Rueda / wheel:
Trasera / rear

Aplicación / application:
Kenworth Dina 9400 SERIE 651

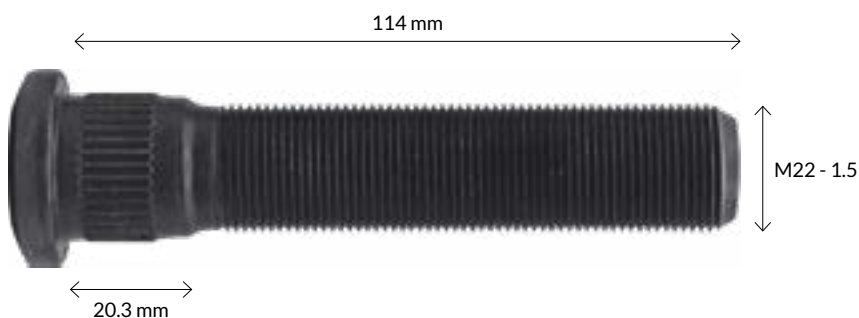
BM-M22-00120-RX

Rueda / wheel:
Trasera / rear

Otros / others:
1 9727 R 2 99-727 3 50-082A

Aplicación / application:
Rin aluminio, eje remolque / Aluminium rim, Axle trailer

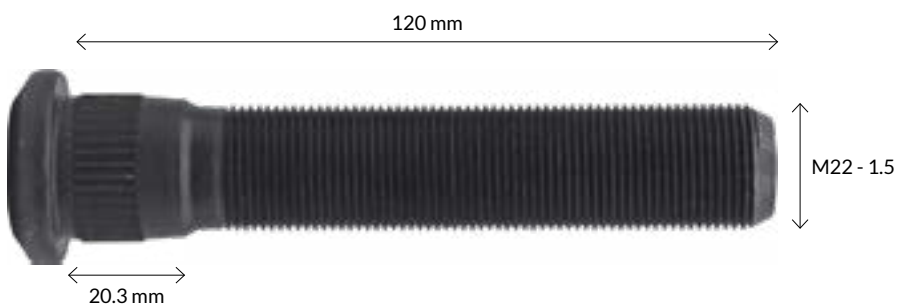
BM-M22-00130

Rueda / wheel:
Trasera / rear

Otros / others:
1 9711 R 2 99-711 3 50-083 4 8990

Aplicación / application:
Tracto camión serie 6-7 / Tract truck series 6-7

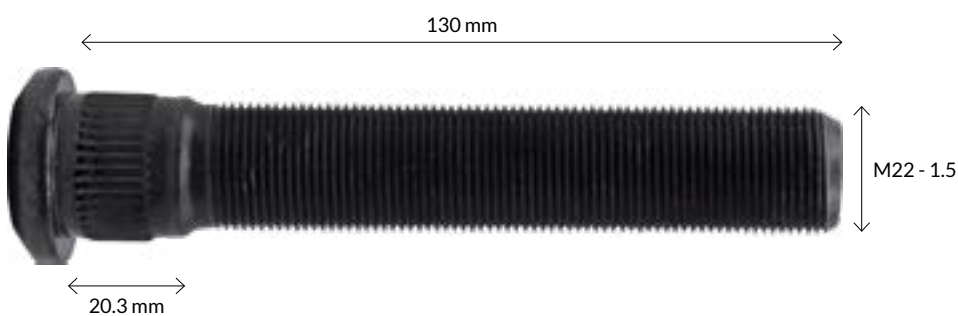
BM-M22-00100-C

Rueda / wheel:
Trasera / rear

Otros / others:
1 9729 R 2 99-729 3 50-105A

Aplicación / application:
Tractocamiones serie 6, 7 rin acero
/ Tract truck series 6-7 steel rim

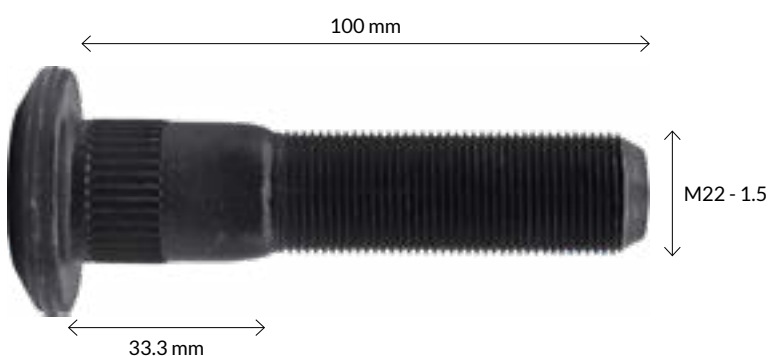

BM-M22-00100-H

Rueda / wheel:
Trasera / rear

Otros / others:
1 9058R 2 99-058 3 50-105

Aplicación / application:
Dirona 9400 Kenworth

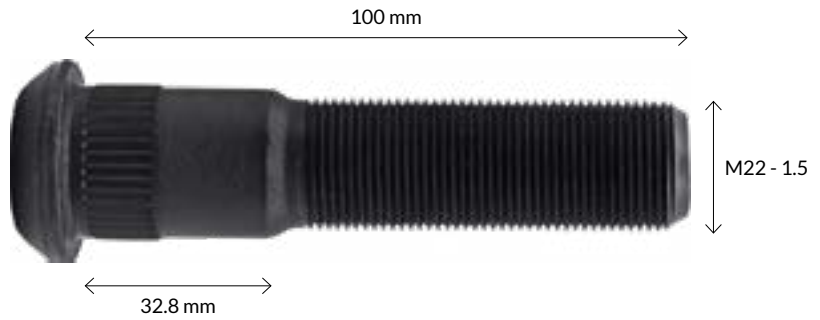

BM-M22-00106-H

Rueda / wheel:
Trasera / rear

Otros / others:
1 9065 2 99-065 3 50-076 5 13-1577 6 M3667

Aplicación / application:
Dina 9400 Kenworth Serie 651

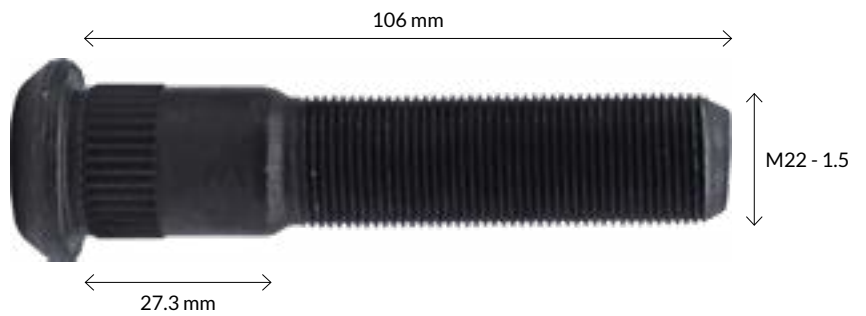

BM-M22-00107-H

Rueda / wheel:
Trasera / rear

Aplicación / application:
Dirona 9400 Kenworth 651

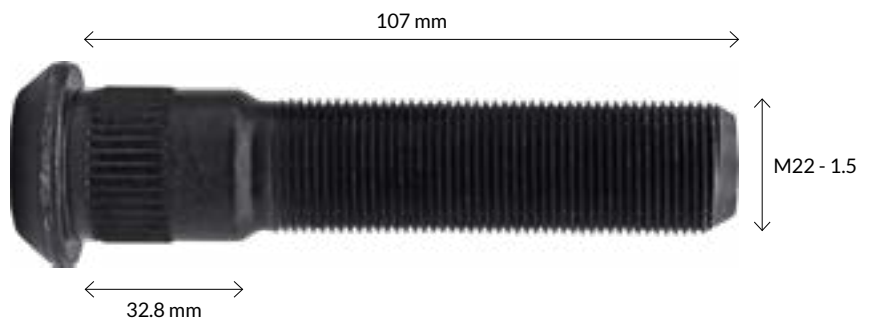

BM-M22-00089-HC

Rueda / wheel:
Delantera / front wheel

Otros / others:
2 99-089 3 50-101

Aplicación / application:
Tractores 6 y 7 rin acero / 6 y 7 steel rim tractors.

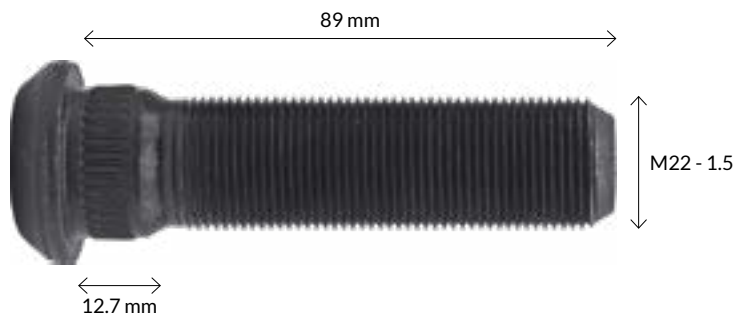

BM-M22-00108-HC

Rueda / wheel:
Delantera / front wheel

Otros / others:
2 99-070 3 50-100

Aplicación / application:
Eje Rockwell / Rockwell axis

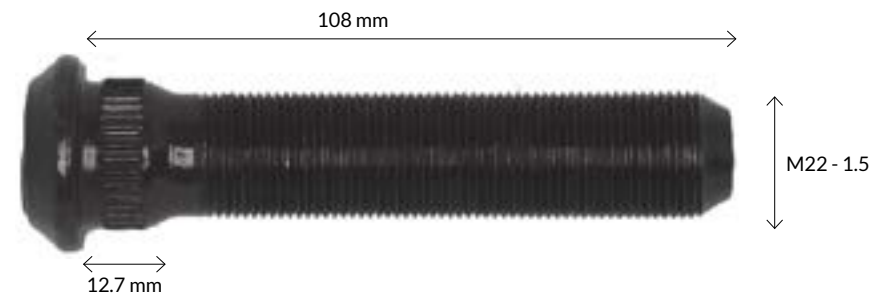

BM-M22-00095-F

Rueda / wheel:
Delantera / front wheel

Otros / others:
1 9740 R 2 99-740 3 50-112

Aplicación / application:
Suspensión Hendrickson, eje y mazas Heyes Lemmerz /
Hendrixon suspension, axis and mace heyes lemmerz

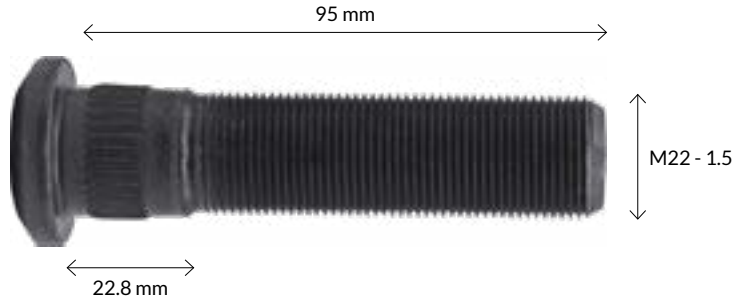

BM-M22-00106-F

Rueda / wheel:
Delantera / front wheel

Otros / others:
2 99-081

Aplicación / application:
Servicio extrapesado / Extra Heavy Duty

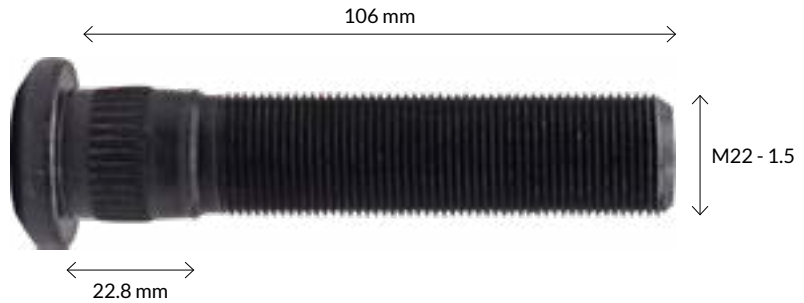

BM-M22-00120-F

Rueda / wheel:
Delantera / front wheel

Otros / others:
2 99-080 6 M-3202

Aplicación / application:
Sistema Unimount / Unimount system

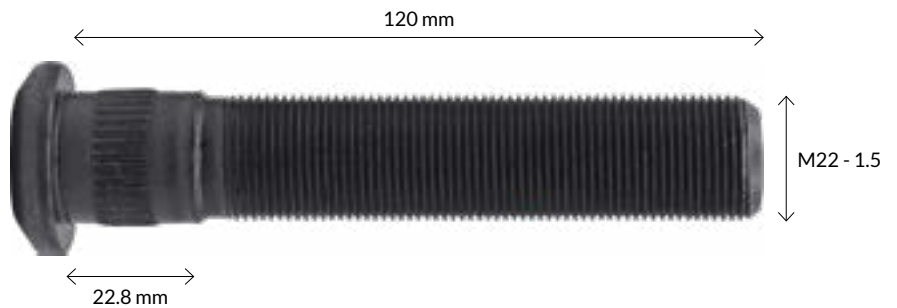

BM-M22-00113.5-C

Rueda / wheel:
Trasera / rear

Otros / others:
1 9741 R 2 99-077 3 50-107
4 10219 6 M-3659

Aplicación / application:
Euclid 10219 año 03-05 / Euclid 10219 year 03-05



BM-M22-00139-FC

Rueda / wheel:
Trasera / rear

Otros / others:
1 9739 R 2 99-069 3 50-084
4 10221 5 13-1552 6 M-3663

Aplicación / application:
Rueda trasera modelo extrapesado
/ Extra heavy duty rear wheel

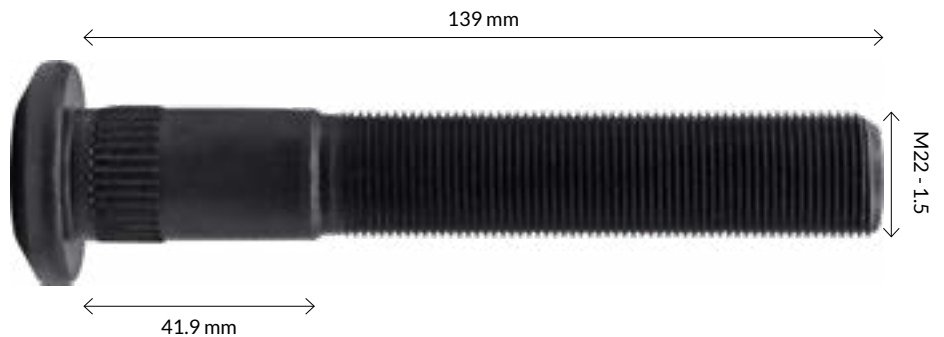

BM-M22-00080-FC

Rueda / wheel:
Trasera / rear

Otros / others:

- 1 9731 R
- 2 99-731
- 3 50-114

Aplicación / application:

Eje Rockwell, eje Meritor 2800 y 3200 Lbs Tracto / Rockwell axis, meritor axis, tracto 2800 y 3200 lbs



BM-M22-00087-ME

Rueda / wheel:
Delantera / front wheel

Otros / others:

- 2 99-073
- 3 50-111

Aplicación / application:

Especial / Special

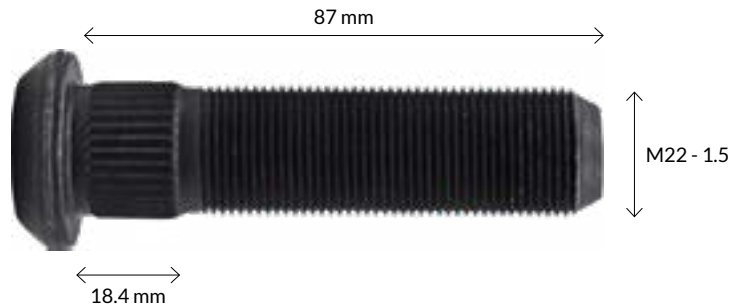

BML-M22-00088

Rueda / wheel:
Delantera / front wheel

Otros / others:

- 1 9717 R
- 2 99-717
- 3 50-080A

Aplicación / application:

Tracto camión serie 6 y 8, rin acero, Dina, Kenworth 2000 / Truck series 6 and 8 steel rim, Dina, Kenworth 2000

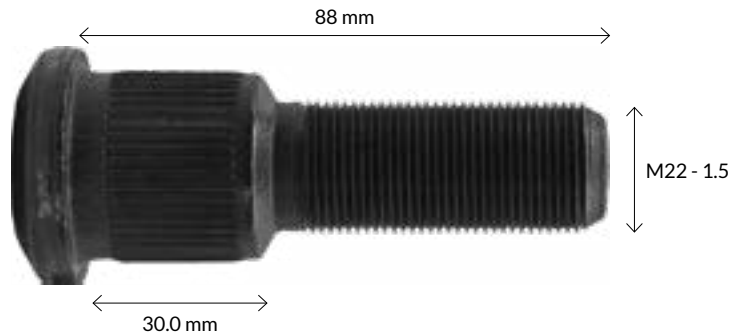

BML-M22-00100

Rueda / wheel:
Delantera / front wheel

Otros / others:

- 1 9715 R
- 2 99-715
- 3 50-080
- 5 13-1720

Aplicación / application:

Tracto camión serie 6 y 8, rin acero, Dina, Kenworth 2000 / Truck series 6 and 8 steel rim, Dina, Kenworth 2000

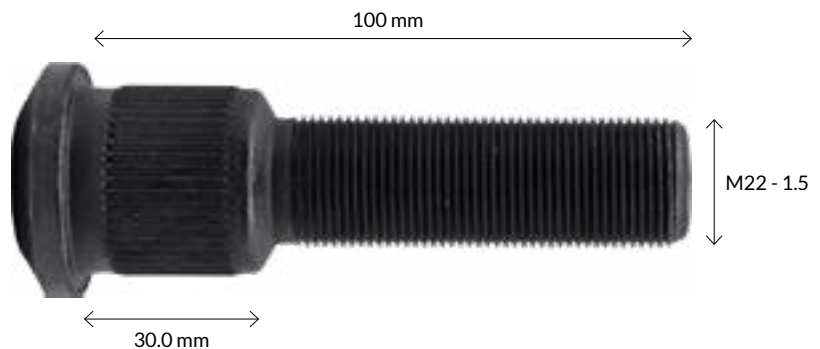

BML-M22-00113

Rueda / wheel:
Delantera / front wheel

Otros / others:

- 1 9713 R
- 2 99-713
- 3 50-081
- 4 8986
- 5 13-1721
- 6 M-3677

Aplicación / application:
Tracto camión serie 6 y 7, rin aluminio, dina / Truck series 6 and 7 steel rim, Dina

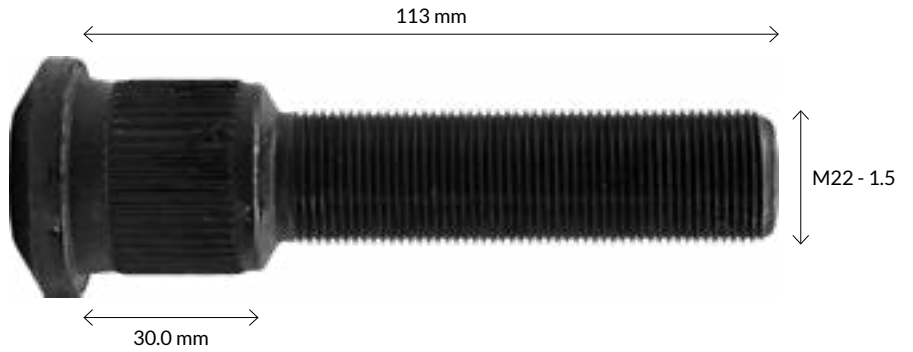

BM-M22-00090-CP

Rueda / wheel:
Delantera / front wheel

Otros / others:

- 2 99-081

Aplicación / application:
Servicio extrapesado / Extra Heavy Duty



BM-M22-00107-CP

Rueda / wheel:
Trasera / rear

Otros / others:

- 1 9744 R
- 2 55-620
- 3 50-108
- 4 5993
- 5 13-1560
- 6 M-3206

Aplicación / application:
Euclid 5993 año 03/05 / Euclid 5993 year 03/05

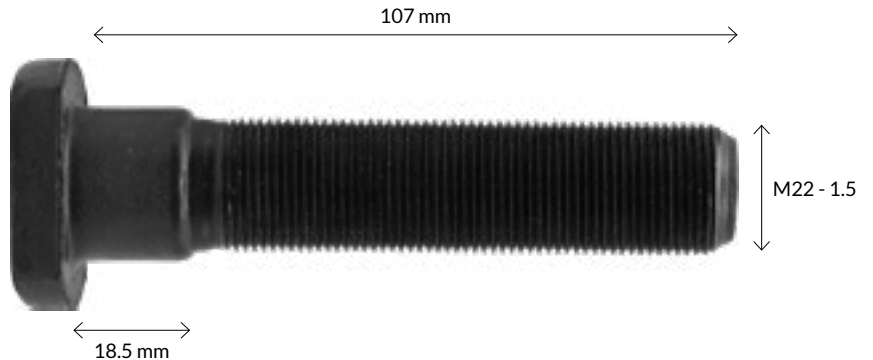

BM-M22-00121-CP

Rueda / wheel:
Trasera / rear

Otros / others:

- 2 55-621
- 3 50-109
- 4 8997

Aplicación / application:
Euclid 8997

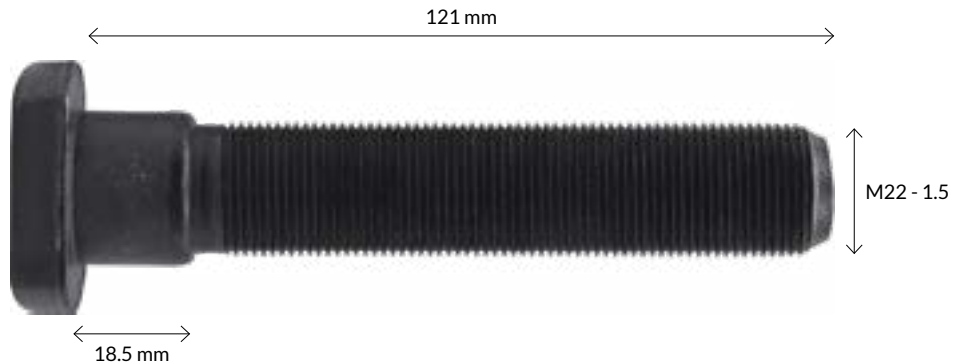

BM-M22-00076

Rueda / wheel:
Delantera / front wheel

Otros / others:

- 1 500 R
- 2 99-061
- 3 50-077
- 5 13-2832

Aplicación / application:
Autobus Mercedes Benz / Mercedes Benz bus



BM-M22-00089

Rueda / wheel:
Delantera / front wheel

Otros / others:

- 1 501 R
- 2 99-060
- 3 50-077A

Aplicación / application:
Autobus Mercedes Benz rin de aluminio año 90/93
/ Mercedes Benz bus aluminium rim year 90/93



BM-M22-00098

Rueda / wheel:
Trasera / rear

Otros / others:

- 1 502 R
- 2 99-059
- 3 50-078
- 5 13-2837

Aplicación / application:
Autobus Mercedes Benz / Mercedes Benz bus



BM-M22-00119

Rueda / wheel:
Trasera / rear

Otros / others:

- 1 502E R
- 2 99-066
- 3 50-079
- 5 13-2835

Aplicación / application:
Autobus Mercedes Benz rin de aluminio año 90/93
/ Mercedes Benz bus aluminium rim year 90/93



BM-M22-00086-SM

Rueda / wheel:
Delantera / front wheel

Otros / others:
1 9747R
2 99-086
3 50-116
4 10256

Aplicación / application:
Eje Rockwell / Rockwell axis

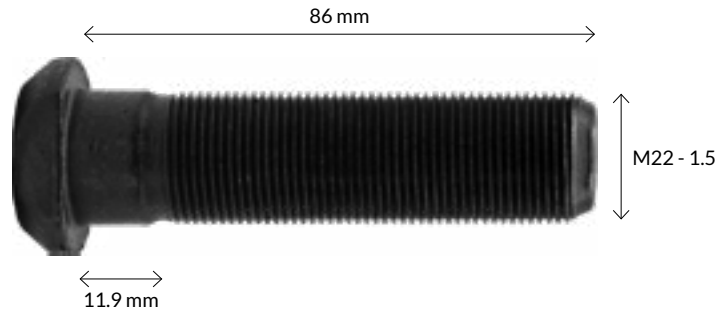

BM-M22-00098-SM

Rueda / wheel:
Trasera / rear

Otros / others:
2 99-087
3 50-117

Aplicación / application:
Eje Rockwell / Rockwell axis

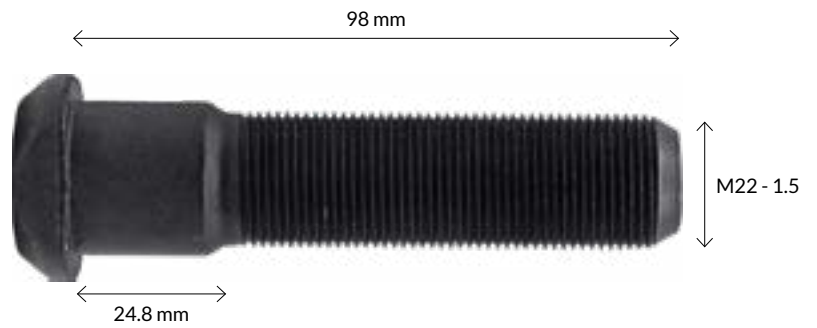

BMA-M22-00089

Rueda / wheel:
Delantera / front wheel

Otros / others:
1 9056 R
2 99-056
3 50-075

Aplicación / application:
Kenworth Dina 9400 serie 651 para maza de aluminio, rin acero / Kenworth Dina 9400 series 651 for aluminium hub, steel rim

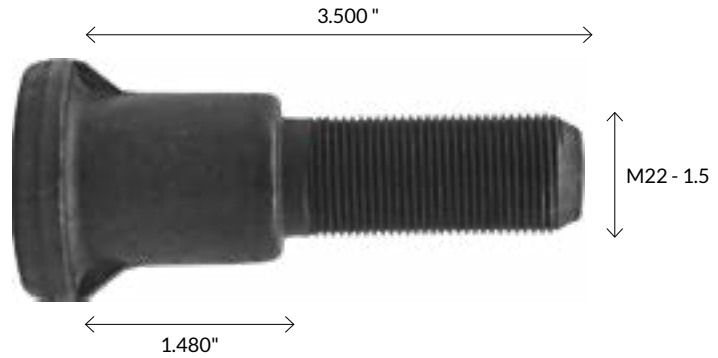

BMA-M22-00102

Rueda / wheel:
Delantera / front wheel

Kenworth Dina 9400 serie 651 para maza de aluminio, rin acero / Kenworth Dina 9400 series 651 for aluminium hub, steel rim

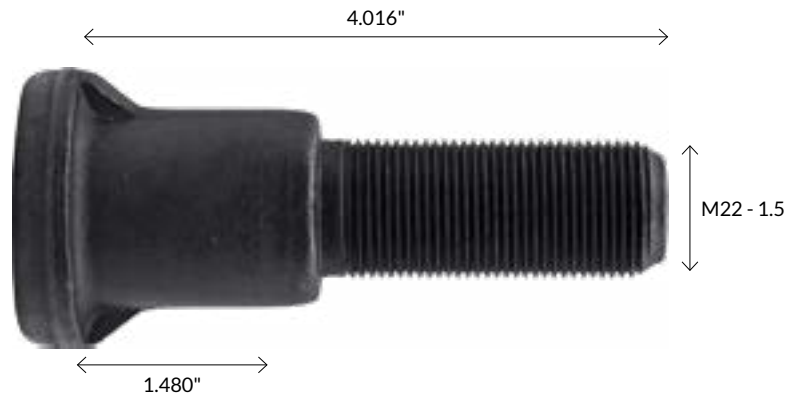

BIRLOS TOPE

/ DOUBLE - ENDED CLIPPED COLLAR SHOULDER STUDS

BT-I-03590 D/I**Rueda / wheel:** Trasera / rear**Otros / others:**1 2011 R, 2012 L 2 22-011, 22-012 3 50-001 R, 50-002 L
4 5556R, 5556L 5 13-002R, 13-002L 6 M-48, M-49**Aplicación / application:**

Camión todos, caja remolque / All trucks, trailer box

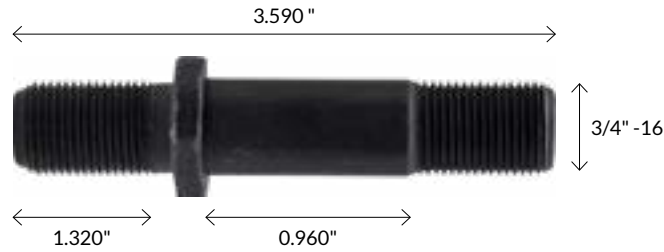
**BT-I-03950 D/I****Rueda / wheel:** Trasera / rear**Otros / others:**1 5041 R, 5042 L 2 55-041, 55-042 3 50-005 R,
50-006 L 4 5561R, 5561L 5 13-004R, 13-004L
6 M-52, M-53**Aplicación / application:**

Autobus maza / Bus hub

**BT-I-04240 D/I****Rueda / wheel:** Trasera / rear**Otros / others:**1 5047 R, 5048 L 2 55-047, 55-048 3 50-007 R, 50-008
L 4 5551R, 5551L 5 1306R, 1306L 6 M-56, M-57**Aplicación / application:**Camión todos, caja remolque, rin acero / All trucks, trailer
box, steel rim**BT-I-04629 D/I****Rueda / wheel:** Trasera / rear**Otros / others:**1 5045 R, 5046 L 2 55-045, 55-046 3 50-011 R, 50-012
L 4 5553R, 5554L 5 13-008R, 13-008L 6 M-60, M-61**Aplicación / application:**Ramirez, Fruehauf, White Maza autobus, caja
remolque / Trailer box**BT-I-05115 D/I****Rueda / wheel:** Trasera / rear**Otros / others:**1 5049 R, 5050 L 2 55-049, 55-050 3 50-015 R, 50-
016 L 4 5557R, 5557L 5 1309R, 1309L 6 M-62, M-63**Aplicación / application:**Eje Ramirez V2000 Sencillo, Tractocamiones
/ Ramirez axis V2000 Simple, trucks

BT-I-05125-E D/I

Rueda / wheel:
Trasera / rear

Otros / others:

2 55-510, 55-511 3 50-328 R, 50-329 L 4 5933R, 5933L 5 13-1040R, 13-1040L 6 M-2408, M-2409

Aplicación / application:

Euclid 5933 R, Euclid 5933 L



BT-I-05250-E D/I

Rueda / wheel:
Trasera / rear

Otros / others:

1 5037 R, 5038 L 2 55-037, 55-038 3 50-013 R, 50-014 L

Aplicación / application:

Ramirez Fruehauf, White Maza autobus, caja remolque, rin aluminio

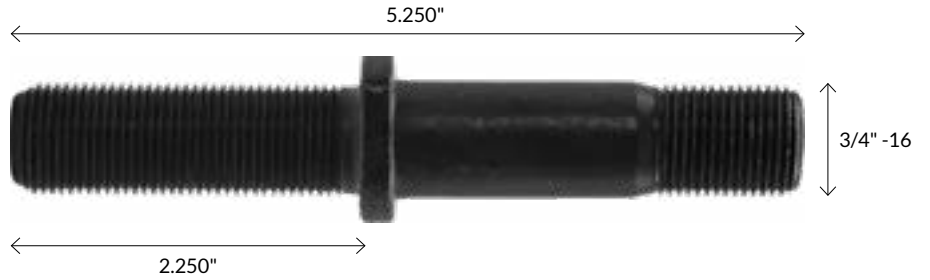

BTM-I-03590 D/I

Rueda / wheel:
Trasera / rear

Otros / others:

1 5145 R, 5146 L 2 55-145, 55-146 3 50-017 R, 50-018 L 4 5714R, 5714L 5 1302R, 1302L 6 M-1166, M-1167

Aplicación / application:

Kenworth eje Shuler, caja remolque / Kenworth axis, Shuler, trailer



BTM-I-03950 D/I

Rueda / wheel:
Trasera / rear

Aplicación / application:

autobus maza con moleteado / Bus hub with knurling



BTM-I-04629 D/I

Rueda / wheel:
Trasera / rear

Otros / others:

1 5143 R, 5144 L 2 55-143, 55-144 3 50-019 R, 50-020 L 4 5717R, 5717L 5 1305R, 1305L 6 M-2496, M-2497

Aplicación / application:

Eje Rockwell / Rockwell axis



BIRLOS MAZA 3/4"

/ 3/4" STUDS

BMI-02438 D/I

Rueda / wheel:
Delantera / front wheel

Otros / others:
1 3015 / 1005, 3016 / 1006
2 33-015, 33-016
3 30-051 R, 30-052 L
6 M-74, M-75

Aplicación / application:
F-500 / F-600



BMI-02880 D/I

Rueda / wheel: Trasera / rear

Otros / others: 1 5139 R, 5140 L 2 55-139, 55-140
3 50-049 R, 50-050 L 4 4967R, 4967L 5 13-1107R,
13-1107L 6 M-78, M-79

Aplicación / application:
Eje Rockwell / Rockwell axis



BMI-02880-E D/I

Rueda / wheel: Trasera / rear

Otros / others: 2 55-603, 55-604 3 50-310, 50-311
4 4968R, 4968L

Aplicación / application:
Eje Rockwell / Rockwell axis

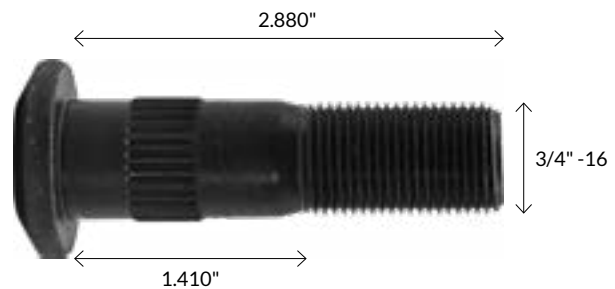

BMI-03120 D/I

Rueda / wheel: Trasera / rear

Otros / others: 1 5139 A R, 5140 A L 2 55-239,
55-240 3 50-049A R, 50-050A L 4 8982R, 8982L
5 13-1146R, 13-1146L 6 M-3612, M-3613

Aplicación / application:
Eje Rockwell / Rockwell axis



BMI-03120-E D/I

Rueda / wheel: Trasera / rear

Otros / others: 2 29-562, 29-563 3 50-049B, 50-050B

Aplicación / application:
Eje Rockwell / Rockwell axis



BMI-03187 D/I

Rueda / wheel: Trasera / rear

Otros / others: 1 8136N R, 8137N L 2 55-605, 55-606
3 50-314 R, 50-315 L 4 8957AR, 8957AL

Aplicación / application:
Euclid 8957 AR, Euclid 8957 AL



BMI-03375 D/I

Rueda / wheel: Trasera / rear

Otros / others: 1 5147 R, 5148 L 2 55-147, 55-148 3 50-051 R, 50-052 L 4 5765R, 5765L 6 M-1120, M-1121

Aplicación / application:
Caja Fruehauf / Freuehauf box



BMI-03406 D/I

Rueda / wheel:
Trasera / rear

Otros / others:
2 55-183, 55-184 3 50-335 R, 50-336 L 4 10208R,
10208L 5 13-1157R, 13-1157L 6 M-3652, M-3653

Aplicación / application:
Freightliner

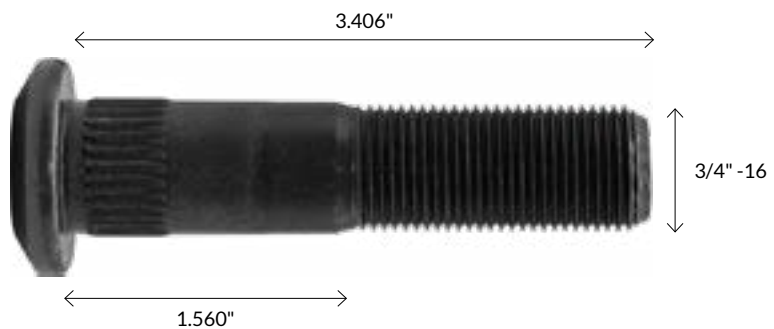

BMI-03460 D/I

Rueda / wheel:
Trasera / rear

Otros / others:

1 5139AE R, 5140AE L 2 55-339, 55-340 3 50-049C R, 50-050C L

Aplicación / application:

Eje rockwell rin aluminio, rin acero
/ rockwell axis aluminium rim, steel rim

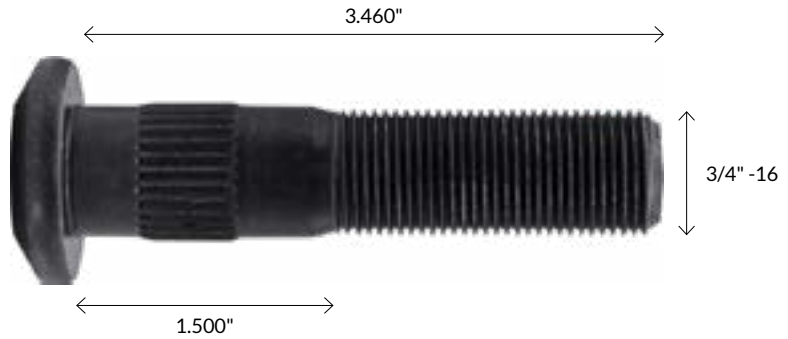

BMI-03825 D/I

Rueda / wheel:
Trasera / rear

Otros / others:

1 5149E R, 5150E L 2 55-249, 55-250
3 50-055 R 50-056 L 5 13-1176R, 13-1176L

Aplicación / application:

Eje Rockwell / Rockwell axis



BMI-03825-E D/I

Rueda / wheel:
Trasera / rear

Otros / others:

1 5149 R, 5150 L 2 55-149, 55-150 3 50-053 R, 50-054 L

Aplicación / application:

Eje Rockwell Freightliner, Torton
/ Rockwell axis, Freightliner, Torton

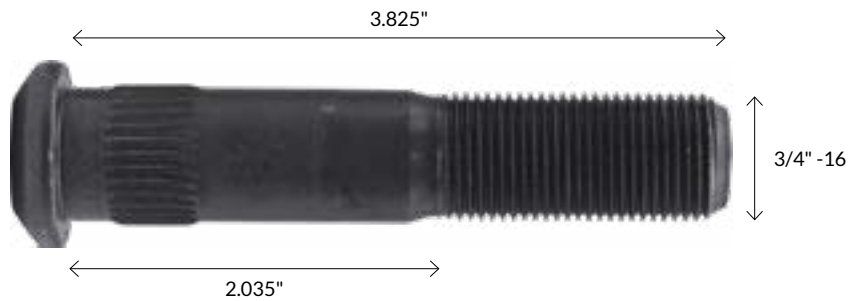

BM-I-02406 D/I

Rueda / wheel:
Trasera / rear

Otros / others:

1 8111 R, 8112 L 2 88-111, 88-112 3 50-057 R, 50-058 L 6 M-84, M-85

Aplicación / application:

Eje Rockwell / Rockwell axis 20 X 206,
Eje Rockwell / Rockwell axis 20 X 207



BM-I-02750 D/I

Rueda / wheel:
Delantera / front wheel

Otros / others: 1 5043 R, 5044 L 2 55-043, 55-044
3 50-033 R, 50-034 L 4 5720R, 5720L 5 13-1203R,
13-1203L 6 M-88, M-89

Aplicación / application:
Autocar, Ramirez, Sultana Eje Timken, Kenworth



BM-I-03281 D/I

Rueda / wheel:
Trasera / rear

Otros / others: 1 5101 R, 5102 L 2 55-101, 55-102
3 50-035 R, 50-036 L 4 5910R, 5910L 5 13-1204R,
13-1204L 6 M-2436, M-2437

Aplicación / application:
Dina Autobus 300



BM-I-03500 D/I

Rueda / wheel:
Trasera / rear

Otros / others: 1 5101 A R, 5102 A L 2 55-111, 55-112
3 50-037 R, 50-038 L

Aplicación / application:
Dina Autobus 300, rin Aluminio
/ Dina bus 300, aluminium rim



BML-I-02950 D/I

Rueda / wheel:
Trasera / rear

Otros / others: 1 8117N R, 8118N L 2 H88-117, H88-
118 3 50-061 R, 50-062 L 4 5987R, 5987L 5 13-1234R,
13-1234L 6 M-1288, M-1289

Aplicación / application:
Motor Wheel



BML-I-03125 D/I

Rueda / wheel:
Trasera / rear

Otros / others: 1 8105N R, 8106N L 2 H88-105, H88-
106 3 50-067 R, 50-068 L 4 5871R, 5871L
5 13-1230R, 13-1230L 6 M-1212, M-1213

Aplicación / application:
Eje Rockwell, Motor Wheel, Eje Kenworth, Peter Bilt
/ Rockwell axis, motor wheel. Kenworth axis, Peter bilt



BML-I-03187-E D/I

Rueda / wheel:
Trasera / rear

Otros / others:

1 8109N R, 8110N L 2 H88-109, H88-110 3 50-063
R50-064 L 4 6057 R, 6057 L 5 13-2535R, 13-2535L
6 M-3626, M-3627

Aplicación / application:
Caja Fruehauf / Fruehauf box



BML-I-03500 D/I

Rueda / wheel:
Trasera / rear

Otros / others:

1 8107N R, 8108N L 2 H88-107, H88-108 3 50-069 R,
50-070 L 4 5896R, 5896L 5 13-1231R, 13-1231L
6 M-2438, M-2439

Aplicación / application:
Eje Rockwell, Motor Wheel, Eje Kenworth, Peter Bilt /
Rockwell axis, motor wheel. Kenworth axis, Peter Bilt

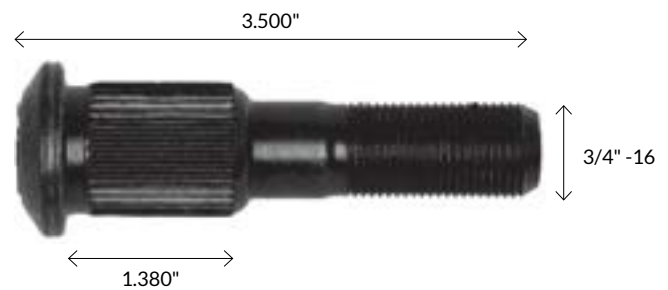

BML-I-03750 D/I

Rueda / wheel:
Trasera / rear

Otros / others:

1 8115N R, 8116N L 2 H88-115, H88-116 3 50-071 R,
50-072 L 4 5983R, 5983L 5 13-1232R, 131232L
6 M-2466, M-2467

Aplicación / application:
Peter Bilt 03-02 852, Peter Bilt 03-02 853

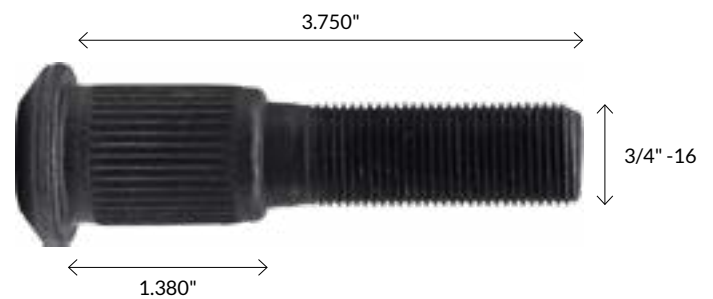

BM-I-03160 D/I

Aplicación / application:
Maza Tractor eje Motriz / Maza de aluminio
/ Hub tractor, drive shaft, aluminium hub



BM-I-03234 D/I

Rueda / wheel:
Delantera / front wheel, trasera / rear

Otros / others:

1 8122N R, 8122N L 2 H29-529, H29-530 3 50-085 R,
50-086 L

Aplicación / application:
Freightliner



BM-I-03530 D/I

Rueda / wheel:
Trasera / rear

Aplicación / application:
FREIGHTLINER



BM-I-03812 D/I

Rueda / wheel:
Trasera / rear

Otros / others: 1 8123N R, 8123N L 2 H29-538, H29-539 3 50-087 R, 50-088 L 4 6028R, 6029L 5 13-2373R, 13-2373

Aplicación / application:
FREIGHTLINER



BMA-I-02625 D/I

Rueda / wheel:
Trasera / rear

Otros / others: 1 5131 R, 5132 L 2 H55-131, H55-132 3 50-041 R, 50-042 L 4 9005R, 9005L 5 13-2326R, 13-2326L 6 M-3634, M-3635

Aplicación / application:
Eje Rockwell, rin aluminio / Rockwell axis, aluminium rim



BMA-I-03430 D/I

Rueda / wheel:
Trasera / rear

Otros / others: 1 5137 R, 5138 L 2 H55-137, H55-138 3 50-043 R, 50-044 L 4 5924R, 5924L 5 13-2323R, 13-2323L 6 M-2420, M-2421

Aplicación / application:
Kenworth maza, rin aluminio / Kenworth hub, aluminium rim

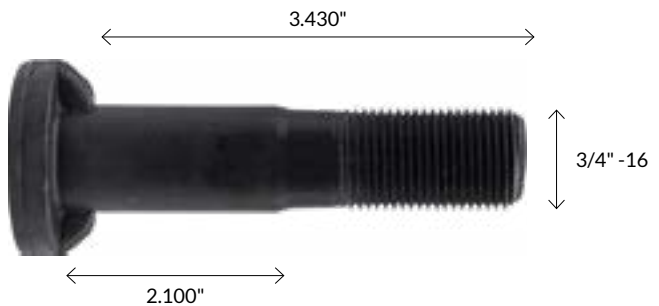

BMA-I-03650 D/I

Rueda / wheel:
Trasera / rear

Otros / others: 1 5133 R, 5134 L 2 H55-133, H55-134 3 50-045 R, 50-046 L 4 5916R, 5916L 5 13-2321R, 13-2321L 6 M-2422, M-2423

Aplicación / application:
Kenworth maza, rin aluminio / Kenworth hub, aluminium rim



BIRLOS MAZA CABEZA RIN ALUMINIO (1-1/8"- 16 UNF)
 / 1-1/8"-16 THREAD. WEDGED HEAD STUD PLAIN BODY TYPE

BMA-P-03500-D/I

Rueda / wheel:

Delantera / front wheel

Otros / others:

- 1 9054 R, 9055 L
- 2 H99-054, H99-055
- 3 50-073 R, 50-074 L

Aplicación / application:

Eje Rockwell, Dirona ,Kenworth, Dina
 / Rockwell axis, Dirona, Kenworth axis, Dina

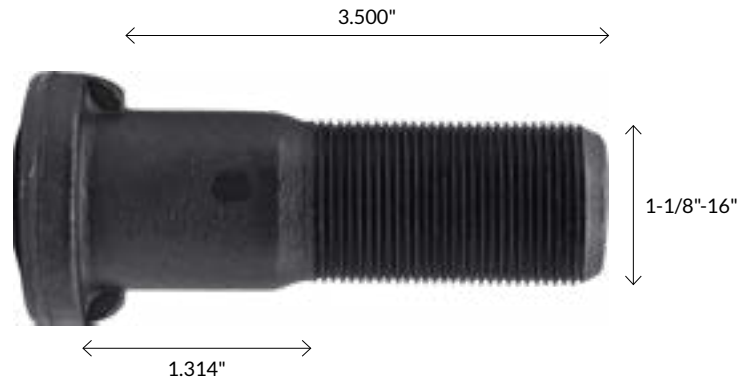

BMA-P-03750-D/I

Rueda / wheel:

Delantera / front wheel

Otros / others:

- 1 9054A, 9055A

Aplicación / application:

Eje Rockwell, Dirona ,Kenworth, Dina
 / Rockwell axis, Dirona, Kenworth axis, Dina

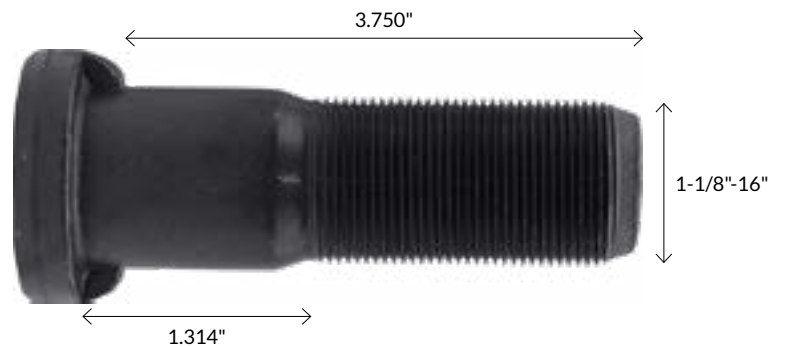

BM-P-02455-D/I

Rueda / wheel: Delantera / front wheel

Otros / others:

- 1 5051R, 5052 L 2 H55-051, H55-052 3 50-023 R,
- 50-024 L 4 5748R, 5748L 5 13-1605R, 13-1605L
- 6 M-1114, M-1115

Aplicación / application:

Ramirez, Autocar, Kenworth



BM-P-02656-D/I

Rueda / wheel: Delantera / front wheel

Otros / others:

1 5103 R, 5104 L 2 H55-103, H55-104 3 50-025 R, 50-026 L 4 5897R, 5897L 5 13-1601R, 13-1601L 6 M-1218, M-1219

Aplicación / application:

Kenworth, Dina 801, Autobus 300 Eje 970 - 975 / Kenworth, Dina 801, bus 300 axis 970 / 975



BM-P-03000-D/I

Rueda / wheel: Delantera / front wheel

Otros / others:

1 5103 A R, 5104 A L 2 H55-113, H55-114 3 50-027 R, 50-028 L 4 5749R, 5749L 5 13-1604R, 13-1604L 6 M-1116, M-1117

Aplicación / application:

Dina 861, Autobus Eje 300, Rin Aluminio, Kenworth / Dina 861, bus axis 300, aluminium rim. Kenworth

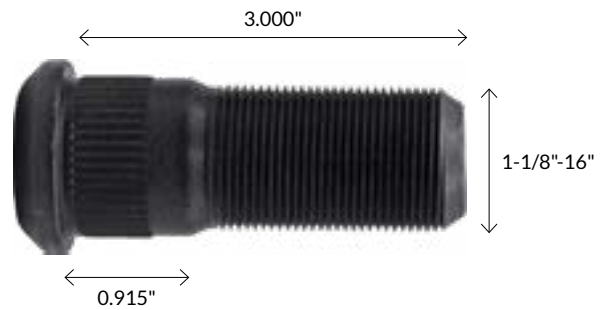

BM-P-03470-D/I

Rueda / wheel: Delantera / front wheel

Otros / others:

1 5141 R, 5142 L 2 H55-141, H55-142 3 50-029 R, 50-030 L 4 9001R, 9001L 5 13-1621R, 13-1621L 6 M-2474, M-2475

Aplicación / application:

Kenworth, eje Fe 970 - 977 / Kenworth, axis Fe 970 - 977

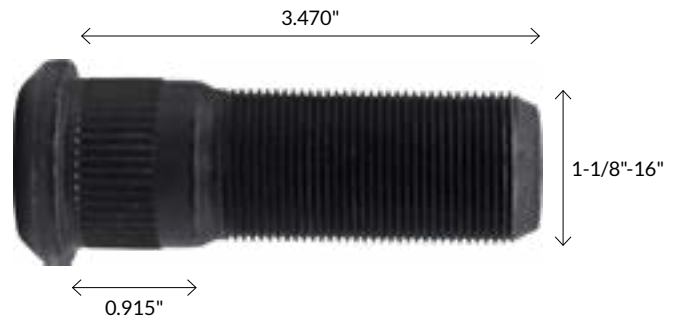

BM-P-03750-D/I

Rueda / wheel: Delantera / front wheel

Otros / others:

2 H55-157, H55-158 3 50-031 R, 50-032 L

Aplicación / application:

Autobuses, tracto, trailers, varios modelos / Buses, tractors, trailers, several models



BM-P-04500-D/I

Rueda / wheel:
Delantera / front wheel

Otros / others:
2 H55-192, H55-193
3 50-031A R, 50-032A L

Aplicación / application:
Autobuses, tracto, rin aluminio, trailers, varios modelos
/ Buses, aluminium rim tractors, trailers, several models

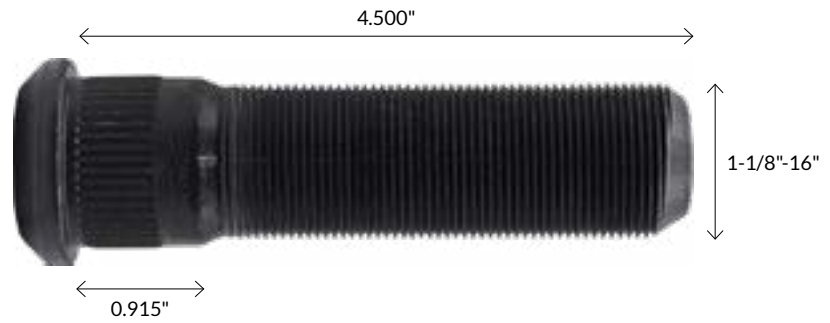

BM-P-03750H-D/I

Rueda / wheel:
Delantera / front wheel

Otros / others:
1 9063 R, 9064 L
2 H55-609, H55-610
3 50-512 R, 50-513 L
4 5982R, 5982L
5 13-1618R, 13-1618L
6 M-2430, M-2431

Aplicación / application:
Rueda delantera modelo extrapesado
/ Front wheel model extra heavy duty

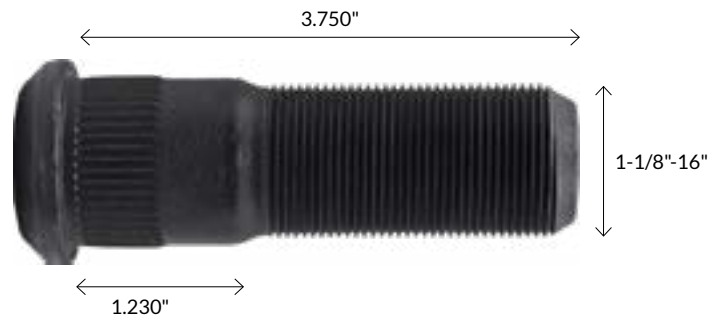

BM-P-04500H-D/I

Rueda / wheel:
Delantera / front wheel

Otros / others:
3 50-512 A R, 50-513 A L

Aplicación / application:
Especial / Special



BM-P-04000HE-D/I

Rueda / wheel:
Delantera / front wheel

Otros / others:
2 H55-522, H55-523
3 50-506 R, 50-507 L

Aplicación / application:
Especial / Special



BM-P-04000HL-D/I

Rueda / wheel:
Delantera / front wheel

Otros / others:
1 5107, 5108
2 H55-155, H55-156
3 50-508A R, 50-509A L

Aplicación / application:
Especial / Special

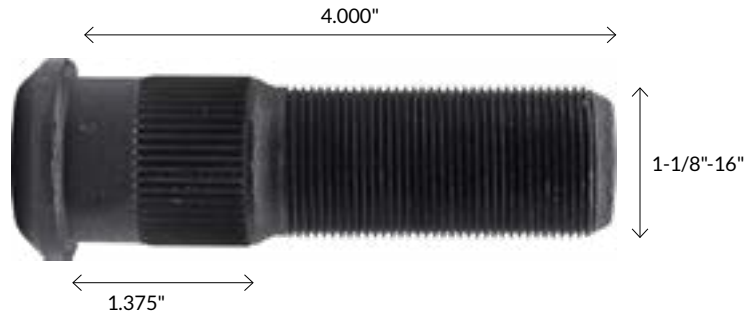

BM-P-04500HL-D/I

Rueda / wheel:
Delantera / front wheel

Otros / others:
1 9061R
2 H55-526, H55-527
3 50-508 R, 50-509 L

Aplicación / application:
Rueda delantera modelo extrapesado
/ Front wheel model extra heavy duty

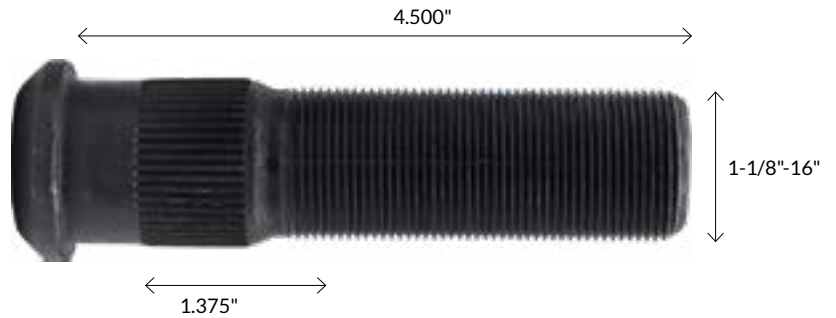

BIRLO MAZA ALUMINIO SCANIA (DIAM 7/8\"-11 BSF)
/ 7/8\"-11 THREAD. SCANIA WHEEL STUD PLAIN BODY TYPE

BM-K-02780-D

Rueda / wheel:
Delantera / front wheel

Otros / others:
1 5151 R 2 H55-151 3 50-090 R 5 13-2957

Aplicación / application:
Autobus Scania / Scania bus



BM-K-03350-D

Rueda / wheel:
Trasera / rear

Otros / others:
1 5152 R 2 H55-152 3 50-091 R 5 13-2956

Aplicación / application:
Autobus Scania / Scania bus



BIRLO MAZA ALUMINIO SCANIA (DIAM 7/8"-14 UNF) / 7/8"-14 THREAD. SCANIA WHEEL STUD PLAIN BODY TYPE

BM-K-03375V-D

Rueda / wheel:
Delantera / front wheel

Otros / others:
1 9735R 2 H55-061 3 50-250 R

Aplicación / application:
Volvo 7550, Volvo 9700



BM-K-04000V-D

Rueda / wheel:
Trasera / rear

Otros / others:
1 9736R 2 H55-062 3 50-251 R

Aplicación / application:
Volvo 7550



TUERCA CAMPANA FLOTANTE MILIMÉTRICA PAVONADA / 2 PIECES 33 MM, M22 X 1.5 BLACKED THREAD FLAGED CAP WHEEL NUT

TF-M22-H3330

Otros / others:
1 IAT-139
2 H12-640
3 TA60-441 R P

Aplicación / application:
Extra pesado / Extra heavy duty



Sistema Unemon / Unemos System

TBM20-H4126-D



TCM30-H4126-D



TCP-P-00875



TC-P-00875



CBP-P-02250-D/I - TROPICALIZADO

Rueda / wheel:
Trasera / rear

Otros / others:
Derecho / Right
1 H23-301
2 CA 00--001 RP
3 38N R

Aplicación / application:
F-350 Doble rodada 1970-96 P-400
/ F-350 double shot year 70-96 P-400



CBP-P-02700-D/I - TROPICALIZADO

Otros / others:
1 38A NR / 39A NL
2 H23-003 / H23-004
3 CA-00-003RT / CA-00-004LT

Aplicación / application:
Extra pesado / Extra heavy duty



CBP-02250-D/I - TROPICALIZADO

Otros / others:
2 H23-001RL / H23-002L
3 CA-00-001 R T / CA-00-002 L T

Aplicación / application:
Budd 10708, Motor Wheel 84525, Ford BB-1132,
Mack 21AX-93, GMC-2201406



CBP-02700-D/I - TROPICALIZADO

Otros / others:
1 39A NL
2 H23-304
3 CA-00-004 L P

Aplicación / application:
Extra pesado / Extra heavy duty



Recomendaciones para el reemplazo de birlos
/ Recommendations for bolts replacements

- | | |
|---|---|
| <ul style="list-style-type: none"> • Los birlos se fracturan generalmente a causa de capuchones flojos o por sobrecargar los vehículos. • Remplace también el birlo que está frente del roto. • Cuando tenga más de un birlo roto se debe cambiar todos los birlos. • Use el torque adecuado y periódicamente revise el estado de los birlos. • Use la longitud correcta del birlo para eliminar fallas de la tuerca. • La correcta longitud del birlo es muy importante sobre todo cuando se usan tuercas de seguridad. • Si la corrosión del birlo es ligera con la limpieza del cepillado puede ser suficiente. • Si la corrosión es extrema remplace la tuerca y el birlo. • Revise periódicamente el aire de las llantas para determinar la cantidad del torque liberado. • Apriete las tuercas a 50 lbs.ft usando las respectivas secuencias ilustradas a continuación. • Usando la misma secuencia apretando las tuercas en incremento de 50 lbs.ft • Use el torque adecuado ilustrado a continuación. | <ul style="list-style-type: none"> • <i>Broken Studs are generally caused by loose cap nuts or vehicle overloading.</i> • <i>Replace studs on either side of broken stud as they likely have been overloaded.</i> • <i>If more than two studs are broken replace entire set.</i> • <i>Use torque recommended in chart and maintain periodic checks.</i> • <i>Inner nuts may fail due to extremely rough service or use of incorrect studs (length).</i> • <i>Using studs with the correct length will eliminate nut failure in most cases.</i> • <i>Correct stud length is critical. If corrosion is slight wire brushing may be sufficient.</i> • <i>If corrosion is excessive replace studs and nuts.</i> • <i>If condition persists lubricate firsts three threads of each stud with graphite-base lubricant.</i> • <i>Do not permit lubricant to get on ball seals of stud holes or on ball face of cap nuts.</i> • <i>Periodically check air wrenches to determine the amount of torque delivered this must be an accurate measurement with no room of error.</i> • <i>Tighten all nuts to 50 lbs.ft. Lbs using repective sequence illustration shown next.</i> • <i>Using same sequence tighten all nuts in increments of 50 lbs.ft.</i> • <i>To recommended torque shown next.</i> |
|---|---|

Modelo Century	B	H	Descripción	Rueda	Tipo de producto
BMM2000053D	BR50-702RP	H55-012	ISUZU CAMION , CLASE 4 MOD ELF 400, 450, 500, 600 , 700	DELANTERA	BIRLO
BMM2000053I	BR50-703LP	H55-013L	ISUZU CAMION , CLASE 4 MOD ELF 400, 450, 500, 600 , 700	DELANTERA	BIRLO
BMM2000067D	BR50-700RP	H55-010	ISUZU CAMION , CLASE 4 MOD ELF 400, 450, 500, 600 , 700	TRASERA	BIRLO
BMM2000067I	BR50-701LP	H55-011L	ISUZU CAMION , CLASE 4 MOD ELF 400, 450, 500, 600 , 700	TRASERA	BIRLO
BMM2000046D	BR50-708RP	H99-751	HINO 300 , TOYOTA COASTER	DELANTERA	BIRLO
BMM2000046I	BR50-709LP	H99-752L	HINO 300 , TOYOTA COASTER	DELANTERA	BIRLO
TBM20H4126D	TA10-192RT	H16-077	ISUZU, ELF 450, ELF 500, ELF 600,	DELANTERA	TUERCA
TBM20H4126I	TA10-193LG	H16-078	ISUZU, ELF 450, ELF 500, ELF 600,	DELANTERA	TUERCA
TCM30H4126D	TA10-190RT	H16-175	ISUZU ELF 400 , ELF 450, ELF 500, ELF 600	TRASERA	TUERCA
TCM30H4126I	TA10-191LG	H16-176	ISUZU ELF 400 , ELF 450, ELF 500, ELF 600	TRASERA	TUERCA
CBH3002540D	CA00-036RT	H23-025	ISUZU ELF 400 , ELF 450, ELF 500, ELF 600	TRASERA	CAPUCHON
CBM3002540I	CA00-037LG	H23-026	ISUZU ELF 400 , ELF 450, ELF 500, ELF 600	TRASERA	CAPUCHON
CBM3002145D	NA	NA		TRASERA	CAPUCHON
CBM3002145I	NA	NA		TRASERA	CAPUCHON

SISTEMAS DE MONTAJE CON RUEDAS / WHEEL MOUNTING SYSTEM

Sistemas de montaje de ruedas con guía de maza (Uni-Mount) / Uni-Mount mounting system

El sistema de montaje de ruedas con guía de maza utiliza una sola tuerca con brida de dos piezas en cada espárrago de la rueda para aplicaciones de rueda única y rueda doble . El sistema de montaje de ruedas con guía de maza también se conoce como Uni-Mount-10™ (10 espárragos), WHD-10™ (10 espárragos).

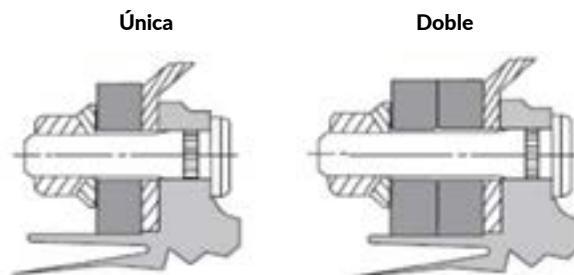

Apriete de tuercas de dos piezas en montaje centrado por maza

/ Two-pieces nut tightening in hub-centered mounting

Tamaño de la rosca de la tuerca	Torque recomendado Lubricado, ft*Lbs
1-1/16" - 16	300-400
7/8" - 14	350-400
M20 X 1.5	280-330
M22 X 1.5	450-500

Sistema de montaje de ruedas de asiento cóncavo (Esferico)

/ Concave seat wheel mounting system

El sistema de montaje de ruedas de asiento cóncavo utiliza el área de contacto esférica entre la tuerca y la rueda para ubicar la rueda y sujetarla firmemente contra el tambor de freno. El sistema de montaje de ruedas de asiento cóncavo también se conoce como sistema con guía de espárrago, tuerca de capuchón de asiento cóncavo (ball seat cap nut, BCN) y tuerca de capuchón doble (double cap nut, DCN), 10 orificios.

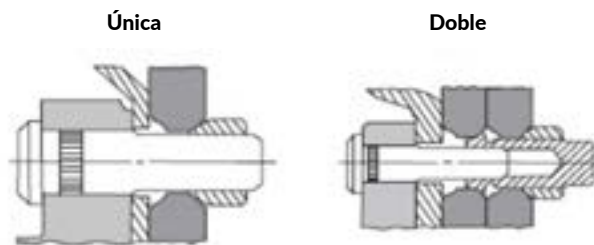

Apriete de tuercas con asiento esférico para montaje centrado por birlo

/ Tightening nuts with spherical seat for centered mounting of stud

Radio de asiento esférico	Tamaño de la rosca	Torque recomendado en seco Lbs*ft
7/8"	3/4" - 16	450-500
7/8"	1-1/8" - 16	450-500
1 - 3/16"	15/16" - 12	750-900
1 - 3/16"	1/18" - 16	750-900
1 - 3/16"	1-5/16" - 12	750-900

PROCESOS EN NUESTRAS LÍNEAS DE PRODUCCIÓN HERRAMIENTAS Y SUJECIONES
/ MANUFACTURING PROCESSING LINE CENTURY STUDS AND TOOLS



Formamos parte de Grupo E.T.S.A. por lo que el tratamiento Térmico de nuestras Herramientas y Sujeciones están bajo las certificaciones IATF-16949 e ISO 9001



TABLA DE CONVERSIONES DE MILÍMETROS A PULGADAS

/ METRIC - STANDARD CONVERSION CHART

Modelo Model	Estriado "	Estriado mm		Mando	A (mm)	B (mm)	L (mm)	Forma Shape	Peso Kg	Empaque	
6.350	1/4"	0.250"		41/64"	0.641"	29.000	-	1.142"	47.625	1-7/8"	1.875"
6.500	-	0.256"	16.500	-	0.650"	29.369	1-5/32"	1.156"	48.000	-	1.890"
6.747	17/64"	0.266"	16.669	21/32"	0.656"	30.000	-	1.181"	48.419	1-29/32"	1.906"
7.000	-	0.276"	17.000	-	0.669"	30.163	1-3/16"	1.188"	49.000	-	1.929"
7.144	9/32"	0.281"	17.066	43/64"	0.672"	30.956	1-7/32"	1.219"	49.213	1-15/16"	1.938"
7.500	-	0.295"	17.463	11/16"	0.688"	31.000	1-1/8"	1.220"	50.000	-	1.969"
7.541	19/64"	0.297"	17.859	45/64"	0.703"	31.750	1-1/4"	1.250"	50.006	1-31/32"	1.969"
7.938	5/16"	0.312"	18.000	-	0.709"	32.000	-	1.260"	50.800	2"	2.000"
8.000	-	0.315"	18.256	23/32"	0.719"	32.544	1-9/32"	1.281"	51.000	-	2.008"
8.334	21/64"	0.328"	18.500	-	0.728"	33.000	-	1.299"	51.594	2-1/32"	2.031"
8.500	-	0.335"	18.653	47/64"	0.734"	33.338	1-5/16"	1.313"	52.000	-	2.047"
8.731	11/32"	0.344"	19.000	-	0.748"	34.000	-	1.339"	52.388	2-1/16"	2.063"
9.000	-	0.354"	19.050	3/4"	0.750"	34.131	1-11/32"	1.344"	53.000	-	2.087"
9.128	23/64"	0.359"	19.447	49/64"	0.766"	34.925	1-3/8"	1.375"	53.181	2-3/32"	2.094"
9.500	-	0.374"	19.844	25/32"	0.781"	35.000	-	1.378"	53.975	2-1/8"	2.125"
9.525	3/8"	0.375"	20.000	-	0.787"	35.719	1-13/32"	1.406"	54.000	-	2.126"
9.922	25/64"	0.391"	20.241	51/64"	0.797"	36.000	-	1.417"	54.769	2-5/32"	2.156"
10.000	-	0.394"	20.638	13/16"	0.813"	36.513	1-7/16"	1.438"	55.000	-	2.165"
10.319	13/32"	0.406"	21.000	-	0.827"	37.000	-	1.457"	55.563	2-3/16"	2.188"
10.500	-	0.413"	21.034	53/64"	0.828"	37.306	1-15/32"	1.469"	56.000	-	2.205"
10.716	27/64"	0.422"	21.431	27/32"	0.844"	38.000	-	1.496"	56.356	2-7/32"	2.219"
11.000	-	0.433"	21.828	55/64"	0.859"	38.100	1-1/2"	1.500"	57.000	-	2.244"
11.113	7/16"	0.438"	22.000	-	0.866"	38.894	1-17/32"	1.531"	57.150	2-1/4"	2.250"
11.509	29/64"	0.453"	22.225	7/8"	0.875"	39.000	-	1.535"	57.944	2-9/32"	2.281"
11.906	15/32"	0.469"	22.622	57/64"	0.891"	39.688	1-9/16"	1.563"	58.000	-	2.283"
12.000	-	0.472"	23.000	-	0.906"	40.000	-	1.575"	58.738	2-5/16"	13"
12.303	31/64"	0.484"	23.019	29/32"	0.906"	40.481	1-19/32"	1.594"	59.000	-	2.323"
12.500	-	0.492"	23.416	59/64"	0.922"	41.000	-	1.614"	59.531	2-11/32"	2.344"
12.700	1/2"	0.500"	23.813	15/16"	0.938"	41.275	1-5/8"	1.625"	60.000	-	2.362"
13.000	-	0.512"	24.000	-	0.945"	42.000	-	1.654"	60.325	2-3/8"	2.375"
13.097	33/64"	0.516"	24.209	61/64"	0.953"	42.069	1-21/32"	1.656"	61.000	-	2.402"
13.494	17/32"	0.531"	24.606	31/32"	0.969"	42.863	1-11/16"	1.688"	61.119	2-13/32"	2.406"
13.891	35/64"	0.547"	25.000	-	0.984"	43.000	-	1.693"	61.913	2-7/16"	2.438"
14.000	-	0.551"	25.003	63/64"	0.984"	43.656	1-23/32"	1.719"	62.000	-	2.441"
14.288	9/16"	0.563"	25.400	1"	1.000"	44.000	-	1.732"	62.706	2-15/32"	2.469"
14.500	-	0.571"	26.000	-	1.024"	44.450	1-3/4"	1.750"	63.000	-	2.480"
14.684	37/64"	0.578"	26.194	1-1/32"	1.031"	45.000	-	1.772"	63.500	2-1/2"	2.500"
15.000	-	0.591"	26.988	1-1/16"	1.063"	45.244	1-25/32"	1.781"			
15.081	19/32"	0.594"	27.000	-	1.063"	46.000	-	1.811"			
15.478	39/64"	0.609"	27.781	1-3/32"	1.094"	46.038	1-13/16"	1.813"			
15.875	5/8"	0.625"	28.000	-	1.102"	46.831	1-27/32"	1.844"			
16.000	-	0.630"	28.575	1-1/8"	1.125"	47.000	-	1.850"			

Nota: Para convertir pulgadas a milímetros multiplique por 25.4; para convertir de milímetros a pulgadas; divida 25.4

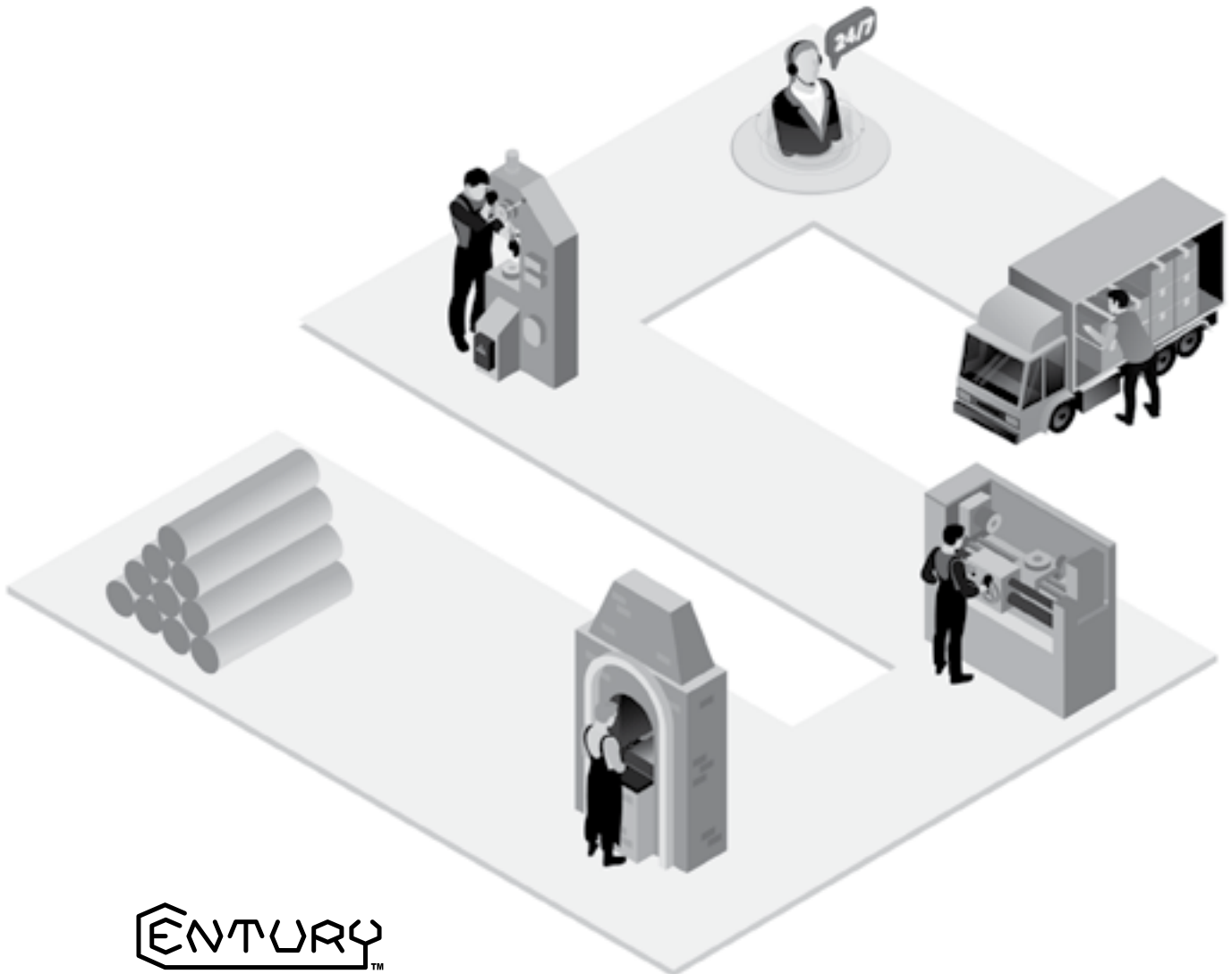
Note: To convert from inches to millimeters, multiply by 25.4; to convert from millimeters to inches, divide over 25.4

CENTURY es la marca preferida de los usuarios que requieren una herramienta profesional de alta resistencia y precisión para el cambio de ruedas. La experiencia en tratamiento térmico de su filial GRUPO ETSA, junto con su amplio conocimiento tanto en forja como en ingeniería, hace posible que **CENTURY** pueda fabricar con calidad extraordinaria y por encima de los requerimientos de las normas automotrices internacionales.

Si alguna de las herramientas **CENTURY** no funciona cuando es utilizada apropiadamente, devuélvala al lugar de compra para su reparación o reemplazo libre de cargo, indicando el motivo de rechazo y proporcionando el comprobante de compra.

La garantía no será aplicable si la herramienta al ser examinada en nuestro laboratorio muestra; un desgaste normal por el tiempo, golpes, abuso, mal uso o alteraciones. Igualmente si al abrir el producto se encuentra deterioro o con uso fuera de lo apropiado, esta garantía no será procedente.

CENTURY is the preferred brand for users who require a heavy duty tool with high strength and precision for the tire service industry. The experience in engineering and forging, together with the experience in heat treatment with CENTURY subsidiary GROUP ETSA, makes it possible to manufacture with extraordinary quality and above the requirements of international automotive standards.

Warranty is valid for any Century products when used properly, if it doesn't work return it to the place of purchase for repair or replacement free of charge. Proof of purchase must be supplied with the reason of the rejection. However, this warranty does not cover any product that has been; abused, normal wear and tear due to weather, altered, misuse, opened, wornout, used for a purpose other than that for which it was intended, or used in a manner inconsistent with instructions regarding use.

Normas usadas para la fabricación de los productos CENTURY:

Professional manufacturing standards for Century products:

ANSI- Herramientas / ANSI-Tools

SAE- Herramientas y elementos de sujeción / SAE Tools and fasteners

La garantía no cubre los siguientes modelos:

This warranty does not cover:

1) El extremo del cuadro de 1/2" de la Llave de cruz **C10C** / *Cross wrench C10C the Outsq 1/2" is not warranty.*

No están garantizados los consumibles / *This warranty does not cover consumable items*

2) Barra de golpe **T26B** / *Beadbreaker slide hammer bar T26B.*

3) Marro talacho **T11EH** y **TG11EH** / *Bead breaker Hammer T11EH and TG11EH*

4) Juego de desmontadora **EJ1 (TN11-TN10-SC)**. / *Tire changing tool and bead keeper EJ1 (TN11-TN10-SC).*

5) Extractor de capuchones **D13, D13F, ET, D5S**. / *Lug stud remover D13, D13F, ET, D5S.*

6) Adaptadores con medidas de mayor a menor como **A1** y **A3** no tiene garantía / *Adapters with measures from highest to lowest such as A1 and A3 there is no guarantee.*

7) Dados de cuadro de 1/2" con pared delgada **SD17, SD19, SD21** y **SD22**. La pared delgada no tiene garantía. / *Sockets 1/2" dr SD17, SD19, SD21 and SD22 with thin wall are not warranty.*

8) Dados de cuadro de 3/4" con pared delgada **SD19T** y **SD21T**. / La pared delgada no tiene garantía. / *Sockets 3/4" dr SD19T and SD21T with thin wall are not warranty.*

Garantía limitada / limited warranty

Los productos si fallan deberán ser revisados por el área técnica de Herramientas **CENTURY**. / *The products if they fail should be reviewed by the CENTURY Tools technical area.*

• Gatos Hidráulicos **GHC12** y **GHC20** reparables en nuestros centros de servicio, 1 año de garantía / *Heavy Duty Bottle Jack GHC12 y GHC20 is fully repairable 1 year warranty.*

• Pistolas Neumáticas **PNP2500, PNT200** y **PNM850**, 6 meses de garantía. / *Heavy duty air neumatic wrenches PNP2500, PNT200 and PNM850 6 months warranty.*

• Multiplicadores de torque **MTO1520** y **MTO7800**, 6 meses de garantía / *Torque multiplier MTO1520 and MTO7800, PNM850 6 months warranty.*

Las Pistolas neumáticas, Multiplicadores y gatos hidráulicos podrán ser reparados o reemplazados de acuerdo al resultado del diagnóstico del área técnica de herramientas **CENTURY**. Esta garantía no aplica si cualquiera de estos productos sufre alteraciones, abrir el producto, se encuentre deteriorado, o usos para própositos fuera de los apropiados.

Bottle Jacks, Pneumatic Guns and Torque Multipliers are guaranteed can be repaired or replaced according to the result of the diagnosis of the technical area of CENTURY tools. This warranty does not cover any product that has been opened, wornout, used for a purpose other than that for which it was intended, or used in a manner inconsistent with instructions regarding use.



Tels: 55•5872•0154 / 55•5870•2255

55•5872•4625 / 55•5872•4637

info@herramientassiglo.com

ventas@centurytools.com.mx

www.centurytools.com.mx

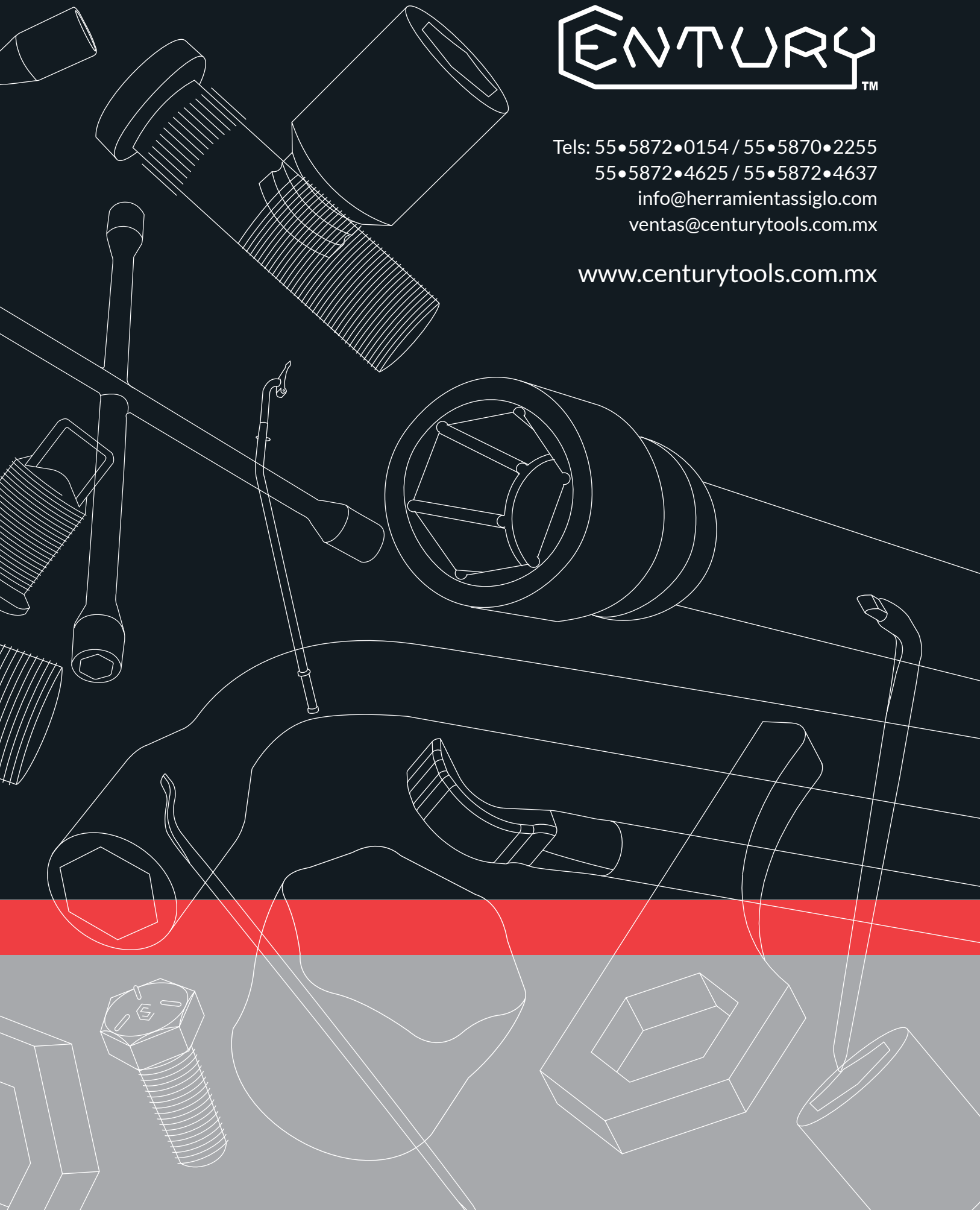



CENTURY™

www.centurytools.com.mx